

# AKW<sup>®</sup>

Resource Center



Full Line Bathroom Catalog

# Life Made Better

We strive to make bathrooms easier to use and safer, more comfortable spaces for seniors, those living with a variety of health conditions, and the caregivers who assist them.

Our team of healthcare specialists and home modification experts know how to create the bathroom you and your family deserve. Here are a few questions to help you start planning your project:

- + Is there enough clear floor space for aided mobility?
- + Does your loved one use an assistive device?
- + Are the bathtub and shower safe to get in and out of?
- + Are the controls reachable, easy to use, and require little strength?
- + Where are the grab bars needed in the bathroom?
- + Is there ample space around the toilet?

The team at AKW benefit from years of industry expertise, a worldwide support network, and robust global supply chain that make us the obvious choice for inclusive bathroom solutions.

Our wide range of accessible bathroom products includes shower seats, grab bars, caregiver doors, shower screens, toilet risers, as well as a large collection of curbless, barrier-free shower bases for seamless access in and out of the shower.

Removing common obstacles and installing intelligent, inclusive accessories can make a huge difference, and help people to retain, and even regain their independence when using the bathroom, which is our ultimate goal – **to make life better.**



Accessible Solutions



Inclusive Accessories



Practical Décor



Nursing Homes



Remodels



Hotels

## Accessible Bathroom Solutions

1

Shower Seats  
PAGE 07

2

Grab Bars  
PAGE 19

3

Shower Screens & Curtains  
PAGE 29

4

Wall Panels & Decor  
PAGE 41

5

Curbless & Low-Level Shower Bases  
PAGE 53



# Why Choose AKW?

For over fifteen years we've proudly supplied distributors across North America with innovative accessible bathroom products that help to make life better for everyone, regardless of their needs, age, or mobility.

Being part of a worldwide group has allowed us to continuously expand our range, which has increased exponentially and includes several products designed exclusively for the US market, such as the Tuff Form Ultimate Linear and Tuff Form Linear Tub Replacement shower bases, and our Pitch Extension Panels.

In addition to providing level-entry, curbless shower bases which make showering easier for people with a variety of needs, we also offer caregiver doors, glass shower screens, stylish grab bars and shower seats, as well as incredibly durable and decorative wall panels and shower niches.

At AKW, we're here to help make life better – it's that simple.







# 01

## Shower Seats

09 Velena Shower Seats

13 2000 Series Shower Seats

15 4000 Series Shower Seats

**Ideal for people in wheelchairs, seniors, or those who are unsteady on their feet, shower seats are an incredibly effective way to make showering an easier, more dignified experience.**

With a number of useful features tailored to meet a variety of specific needs, our range of versatile shower seats has been developed in consultation with occupational therapists, contractors, and people who use the products themselves, to ensure they are as functional and safe as possible.





## Velena Shower Seats



- + Stylish, fold-up design saves space when not in use
- + Adjustable leg model offers a flexible height range, with compact model for smaller spaces
- + Optional Seat Back & Arms ensures greater support and comfort when seated

We believe that aesthetics are equally as important as function when it comes to creating an accessible shower space, which is why Velena Shower Seats have been designed to combine practicality with contemporary styling.

Made from strong, durable materials, Velena Shower Seats can support up to 440lbs with a robust, folding aluminum leg that offers impressive stability, while also vastly reducing the impact of weight loading on the wall and fixings, meaning they're incredibly safe to use.

The ergonomic shaped seat has been designed for comfort as we know showering can often take longer for those with disabilities, and features a discreet water drainage slot for fast drying. The soft-close mechanisms ensure the seat and leg safely fold away when not in use, which is ideal for multi-generational bathrooms.

The Velena Shower Seats collection features several models which are all intended to accommodate a wide range of accessible showering needs.

The Velena Shower Seat offers a standard height of 18 1/2". When unfolded and ready for use, the seat extends 17 2/3" from the wall with a comfortable width of 18 1/4".

Designed for installation in bathrooms where space may be limited, the Velena Shower Seat is also available in a Compact model, with a reduced depth of 14 1/2" and width of 15", and a slightly increased height of just under 19".

For people who require the standard seat size but at a higher or lower height, the Velena Shower Seat with Adjustable Leg can be set to a height of between 16 3/5" – 23 2/3". Please note the height cannot be changed once the seat is installed and fixed to the wall.

When additional support is needed, all models can be ordered with the Velena Seat Back & Arms (**also available a la carte**). This includes a wall-mounted back panel for further comfort and individual fold-up arms which can support up to 175lbs each. Both the back panel and arms can be installed at a height and distance apart that suits the individual for increased flexibility.

All products in the Velena Shower Seat collection are available in a choice of 2 matte colors – bright white and bold black – both featuring cool chrome accents and a satin finish on the aluminum leg.





**Velena Shower Seat**

White	02801-WH
Black	02801-BK



**Velena Compact Shower Seat**

White	02802-WH
Black	02802-BK



**Velena Shower Seat with Adjustable Leg**

White	02810-WH
Black	02810-BK



**Velena Shower Seat Back & Arms**

White	02820-WH
Black	02820-BK

**Velena Shower Seat with Back & Arms**

White	02803-WH
Black	02803-BK

**Velena Shower Seat (Adjustable Leg) with Back & Arms**

White	02811-WH
Black	02811-BK





# 2000 Series Shower Seats



- + Strong, durable yet compact aluminum frame
- + Comfortable, removable foam pads available in two colors
- + Easily folds away to save space when not in use

2000 Series Shower Seats offer comfort, safety and security with a maximum weight capacity of 350lbs, and a medium-duty, slim profile that simply folds away when not in use to save space.

These seats gain their strength from a highly durable, rust-proof aluminum frame and legs, which provide safe and stable support, ensuring the wall fixings are not impacted by weight loading.

Ideal for people who are unsteady on their feet or seniors, the legs allow for height adjustments in 3/4" increments when installing, with the fine-tuning feature on one foot able to compensate for any sloping of the shower base.

All 2000 Series seats feature a molded polyethylene seat that is fitted with removable closed-cell foam pads available in two colors - which is particularly

useful if color contrast is required for people with sight loss or dementia. The pads do not absorb water, even if cut, providing increased comfort and peace of mind.

As the seat and both arms fold up/down independently, they can be quickly and easily adjusted to meet the needs of the person, whether that involves raising a single arm to ensure easy access to the seat, or folding the entire unit against the wall to increase space when entering/exiting the shower.

If grab bars are needed to complete an accessible bathroom, Comfort Grip Grab Bars complement our range of 2000 Series shower seats with most models also offered in white, gray or blue (**see page 27**).



**2000 Series Compact Shower Seat**

Gray	0200OP
Blue	0220OP



**2000 Series Standard Shower Seat**

Gray	0201OP
Blue	0221OP



**2000 Series Standard Shower Seat with Back & Arms**

Gray	0213OP
Blue	0223OP





## 4000 Series Shower Seats



- + Durable and inclusive with strong stainless-steel frames and comfortable seats
- + Seats and arms safely fold away to save space when not in use
- + Broad range of widths, color and shapes to suit different care needs

4000 Series Shower Seats have been designed to enable seniors, people unsteady on their feet, and those living with disabilities to shower comfortably and safely with independence and dignity.

Quick and easy to install, 4000 Series seats are constructed from rust-proof stainless-steel and molded polyethylene, meaning durability and safety are assured, especially as the sturdy legs ensure that wall fixings are not impacted by weight loading.

All seats are rated to support a maximum capacity of 560lbs, with our ADA compliant Extra-Wide Shower Seat designed for larger people of up to 700lbs.

Adjustable-height legs makes individual fit and comfort easy to achieve, with all models generously sized to allow for movement when showering, while staying secure, offering stability for people using wheelchairs when completing side transfers.

Fold-up seats and arms swing safely and independently, meaning users can make adjustments for any situation. For example, position one arm up for easier entry from the side, fold the seat and arms away to make more space when not in use, or place both arms down to maximize security and balance while seated.

Many 4000 Series seats are supplied with removable foam pads that are simple to clean and will not absorb water, even if damaged. These pads are available in gray or blue which provides incredibly beneficial color contrast for people living with sight loss or dementia.

If grab bars are needed to complete an accessible bathroom, Comfort Grip Grab Bars complement our range of 4000 Series shower seats with most models also offered in white, gray or blue (**see page 23**).

### Looking for an ADA compliant shower seat?

The Extra-Wide Shower Seat has been specially designed with larger people in mind, with an increased maximum weight capacity of up to 700lbs, and the same high level of comfort and stability as all our 4000 Series shower seats.

This model is supplied with a removable foam pad available in gray or blue.

### 4000 Series Extra-Wide Shower Seat

Gray	04570P
Blue	04580P







**Wooden Slatted Shower Seat**

Wooden 04030



**4000 Series Standard Shower Seat**

Gray 04270P  
Blue 04070P



**4000 Series Wide Shower Seat**

Gray 04210P  
Blue 04110P



**4000 Series Standard 'U' Shower Seat**

Gray 04200P  
Blue 04100P



**4000 Series Wide 'U' Shower Seat**

Gray 04220P  
Blue 04120P



**4000 Series Standard Shower Seat with Back & Arms**

Gray 04230P  
Blue 04130P



**4000 Series Wide Shower Seat with Back & Arms**

Gray 04240P  
Blue 04140P



**4000 Series Standard 'U' Shower Seat with Back & Arms**

Gray 04260P  
Blue 04160P



**4000 Series Wide 'U' Shower Seat with Back & Arms**

Gray 04250P  
Blue 04150P





---

# 02

---

## Grab Bars

- 21 Rugao Grab Bars
- 23 Comfort Grip Grab Bars
- 25 Specialty Grab Bars
- 27 Fold-Up Support Bars

**The first step in creating a safe, accessible space for people with reduced mobility is often to install a load-bearing grab bar for support with standing, sitting, balancing, and moving around the home.**

Our wide range of grab bars are available in a variety of styles, colors and lengths, and have been designed to be strong and durable, providing reassurance for people with disabilities when they need it most.







# Rugao Grab Bars



- + Chrome-finished bar with brackets in a choice of two stylish colors
- + Minimalist, contemporary design with 4 invisible fixing points
- + Maximum load of 330lbs for safe and reliable support

Rugao Grab Bars are a stylish alternative to traditional looking grab bars that can make accessible bathrooms appear cold and clinical.

Strong yet discreet, these bars can support up to 330lbs and feature a contemporary chrome finish, with the choice of white or dark gray accents within the design to suit a variety of decors.

Available in 3 lengths - 12", 18", 24" – Rugao Grab Bars are quick and simple to install with four hidden fixing points which provide safety, strength, and reliability when its needed most, as well as making them easy to keep clean.

The sleek design enables Rugao Grab Bars to complement other accessible products, such as Velena Shower Seats ([see page 09](#)) and Velena Wall Panels ([see page 43](#)), and FastDEK Shower Bases ([see page 57](#)).

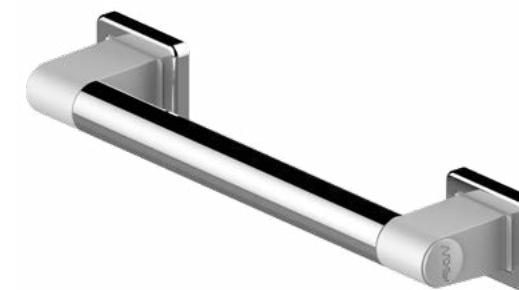

### Rugao Grab Bar 12"

White	12010-WH
Dark Gray	12010-GR

### Rugao Grab Bar 18"

White	12011-WH
Dark Gray	12011-GR

### Rugao Grab Bar 24"

White	12012-WH
Dark Gray	12012-GR



# Comfort Grip Grab Bars



- + Strong steel interior with easy-to-grip fluted exterior
- + Warm-to-touch surface finish available in multiple colors
- + All models meet ADA requirements for accessible bathrooms

Excellent grip and a surface that is warm-to-touch is what sets our Comfort Grip Grab Bars apart from the rest.

Unlike traditional steel bars that can be cold-to-touch and slippery when wet, Comfort Grip Grab Bars offer a warmer alternative that is easy to hold, even when wet, thanks to a fluted vinyl material which overlays the tubular metal core and aids with grip.

For bathrooms where color contrast is required to benefit a person with sight loss or dementia, almost all Comfort Grip Grab Bars are available in white, gray and blue.

As these grab bars are designed to provide strength and stability in accessible bathrooms, each bar has 10 concealed fixing points located beneath bracket covers. All bars have been rated to meet ADA requirements with a maximum capacity of 420lbs.

Incredibly easy to install, Comfort Grip Grab Bars are available in several straight lengths, we also supply angled models, and kits to make it even easier to create a grab bar design tailored to range of spaces and needs.



**Comfort Grip Grab Bar 12"**

White	01900-WH
Blue	01900-BU
Gray	01900-GR



**Comfort Grip Grab Bar 16"**

White	01905-WH
Blue	01905-BU
Gray	01905-GR



**Comfort Grip Grab Bar 18"**

White	01910-WH
Blue	01910-BU
Gray	01910-GR





**Comfort Grip Grab Bar 24"**

White	01920-WH
Blue	01920-BU
Gray	01920-GR



**Comfort Grip Grab Bar 32"**

White	01930-WH
Blue	01930-BU
Gray	01930-GR



**Comfort Grip Grab Bar 36"**

White	01940-WH
Blue	01940-BU
Gray	01940-GR



**Comfort Grip Grab Bar 42"**

White	01950-WH
Blue	01950-BU
Gray	01950-GR



**Comfort Grip Grab Bar 90° Angled**

White	01925-WH
Blue	01925-BU



**Comfort Grip Grab Bar 135° Angled**

White	01915-WH
Blue	01915-BU



**Cut-to-Length Extension Grab Bar Kit 18"**

White	01943-WH
-------	----------



**Cut-to-Length Corner Grab Bar Kit**

White	01942-WH
-------	----------

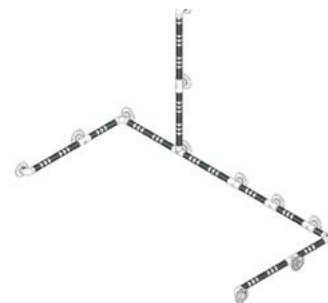

**Cut-to-Length Alcove Grab Bar Kit**

White	01941-WH
-------	----------

# Specialty Grab Bars



- + Incredibly quick and easy to install
- + Variety of accessible designs to suit different care needs
- + Improves safety and balance when moving around the home

Our range of simple, affordable Specialty Grab Bars have been designed to improve safety, mobility, and balance when moving around the home, with unique shapes and a variety of lengths that help to make spaces more accessible for those with disabilities.



**Flat End Grab Bar 12"**

White	01200-WH
Brown	01200-BR



**Flat End Grab Bar 18"**

White	01210-WH
-------	----------



**Cranked Grab Bar 18"**

White	01760-WH
-------	----------



**Cranked Grab Bar 24"**

White	01750-WH
-------	----------



**Newel Grab Bar**

Hand: Left - Ivory	01745-L
Hand: Right - Ivory	01745-R



**Padded Back Rest**

Blue	01190-BU
Gray	01190-GR



## Fold-Up Support Bars



- + Simply and safely folds away when not in use to maximize space
- + Provides invaluable stability when using the toilet or wash basin
- + Ideal for accessible bathrooms with support for up to 440lbs

Fold-Up Support Bars have been designed to provide additional stability when using the toilet or wash basin, with the trombone shape bar allowing people to find the best possible grip and leverage.

Ideal for installation in accessible bathrooms with multiple users, all Fold-Up Support Bars can be held securely in the upright position to save space when not in use, with them releasing safely and easily as and when required.

With a maximum capacity of up to 440lbs, these inclusive support bars have been developed with durability in mind. They also feature a chrome finish or epoxy resin coating, with a rust inhibiting treatment that helps to protect them from water ingress.

Our range of Fold-Up Supports are available with optional toilet roll holders, fixed or adjustable legs, and with multiple color options should there be a need to offer color contrast for someone with sight loss or dementia.



**Fold-up Support with Adjustable Leg**

(max. capacity 440lbs)

White	01830-WH
Blue	01830-BU
Stainless-steel	01830-SS



**Fold-up Support with Fixed Leg**

(max. capacity 440lbs)

White	01820-WH
-------	----------



**Fold-up Support without Leg**

(max. capacity 220lbs)

White	01810-WH
-------	----------





# 03

## Shower Screens & Curtains

- 31 Shower Curtains & Rails
- 33 Caregiver Doors
- 37 Glass Shower Screens

**Our range of durable and highly practical screens help to transform any shower into a beautiful yet accessible space.**

A contemporary Glass Shower Screen is the ideal way to create the illusion of greater space and help with water retention.

For people with additional health requirements that may include needing assistance from a carer or loved one, our bi-fold Caregiver Doors and Breathable Shower Curtains have been designed to make the bathroom a safer, more inclusive place.



# Shower Curtains & Rails

## Breathable Shower Curtains

### + Quick-drying, breathable fabric designed for accessible bathrooms

Breathable Shower Curtains are different from other products because they have been designed for safety, and with those who are unsteady on their feet in mind. Tiny pores in the fabric allow air to pass through, reducing the risk of suffocation should someone fall and become entangled, and providing invaluable reassurance for people with disabilities.

Available in 3 lengths, the curtains hang straight and 'heavy' when wet, so they do not billow out, while also quickly shedding water meaning they dry much faster. All curtains are white in color.

When hung with AKW Hook & Glide Connectors from our Bendy Curtain Rail track, opening and closing is simple, as they are designed for use by people of all abilities.

Product Name	Product Code
Breathable Shower Curtain – 70 3/4" x 74 3/4"	24077
Breathable Shower Curtain – 70 3/4" x 78 3/4"	24078
Breathable Shower Curtain – 70 3/4" x 82"	24079

## Bendy Curtain Rails

### + Shape by hand to suit a variety of inclusive showers

Bendy Curtain Rails are designed for accessible showers that often need additional space to allow for wheelchair access.

The flexible rail can be shaped by hand to fit a wide range of curves, and is offered in 3 lengths which can be cut down on site to suit the installation. All rails are white in color.

Every rail comes with a pair of wall brackets and a drop rod which can also be cut to the preferred length. A pack of 11 Hook & Glide Connectors is also supplied to allow the attached shower curtain(s) to smoothly move along the track with little effort.

Product Name	Product Code
Bendy Curtain Rail – 78"	24033
Bendy Curtain Rail – 98"	24034
Bendy Curtain Rail – 118"	24044
Hook & Glide Connectors (11 pack)	24092





# Caregiver Doors



- + Double bi-fold doors offer greater access for wheelchair users
- + Compatible with all AKW curbless or low-level shower bases
- + Shatterproof plastic panels for increased durability and safety

Caregiver Doors are an innovative, inclusive bathroom solution with half-height (29 1/2") panels enabling carers or loved ones to assist those with disabilities with showering, from outside the shower itself.

Double bi-folding doors open and fold away to maximize the available space when entering/exiting the shower, which is especially beneficial for people using wheelchairs.

Offered in white with clear shatterproof plastic glazing, Caregiver Doors are incredibly durable and lightweight, with 180° rising-butt hinges ensuring a smooth operation.

Easy-grip latch handles designed to be used by people of all abilities, and are also non-handed, making them suitable for left and right-handed users and allowing for greater flexibility in multi-user environments.

Five widths are available to order for alcove shower configurations; if there is a need to fit a slightly larger space, please ask our team about Extra-Wide Compensators which give 4 1/8" extra width and are **available a la carte**.

Caregiver Doors are supplied with an L-shaped Bendy Curtain Rail that can be trimmed down to size and shaped on site, all hardware required to install, two 71" x 71" Breathable Shower Curtains (see **"Breathable Shower Curtains" on page 31**), and two packs of Hook & Glide Connectors.

## Additional Extras

### Replacement Door Handle

24106-WH

### Replacement Door Latch

24105-WH

### Extra-wide Compensator

24130



## Size Options & Product Codes

Product Name	Code	Doors 1 & 4	Doors 2 & 3	Area Height 5	Screen Length 6	Screen Height 7
Alcove Caregiver Doors (29 1/2" x 47 1/4")	91110	11 1/2"	10 1/8"	74"	47 1/4"	29 1/2"
		<b>Minimum Length 46 1/4" Maximum Length 47 3/4"</b>				
Alcove Caregiver Doors (29 1/2" x 51 1/4")	91111	12 1/2"	11 1/8"	74"	54 1/4"	29 1/2"
		<b>Minimum Length 50 1/4" Maximum Length 51 3/4"</b>				
Alcove Caregiver Doors (29 1/2" x 55 7/8")	91113	13 2/3"	12 1/3"	74"	55 7/8"	29 1/2"
		<b>Minimum Length 54 1/4" Maximum Length 56 1/4"</b>				
Alcove Caregiver Doors (29 1/2" x 59")	91114	14 1/2"	13 3/4"	74"	59"	29 1/2"
		<b>Minimum Length 58 1/4" Maximum Length 59 3/4"</b>				
Alcove Caregiver Doors* (29 1/2" x 60")	91115	14 2/3"	13 1/4"	74"	60"	29 1/2"
		<b>Minimum Length 56 3/4" Maximum Length 58 1/4"</b>				

\* Cannot accommodate an extra-wide compensator. Compensators are set at mid-point giving approximately 25" in and out adjustment on both sides.

Non-handed

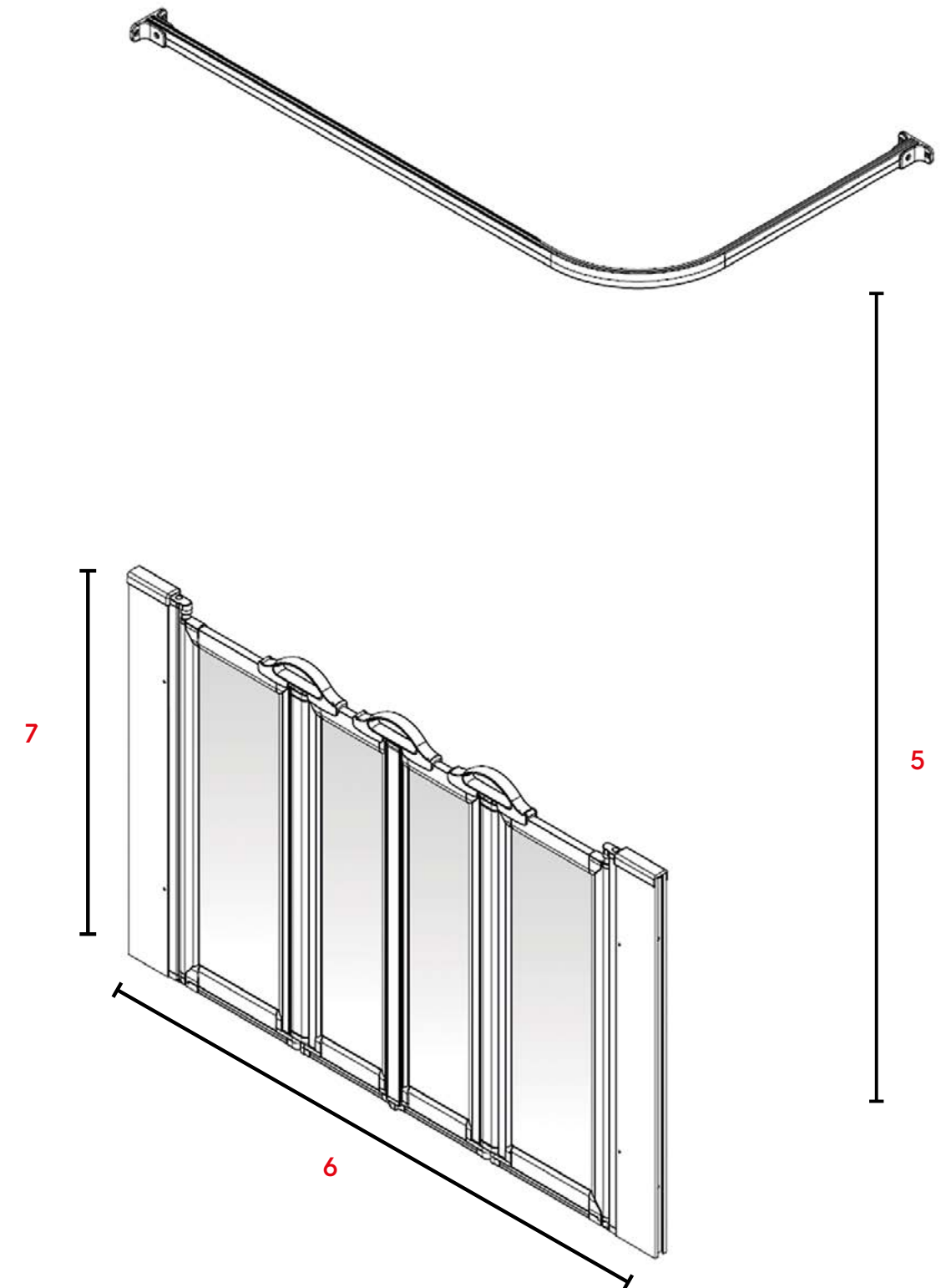
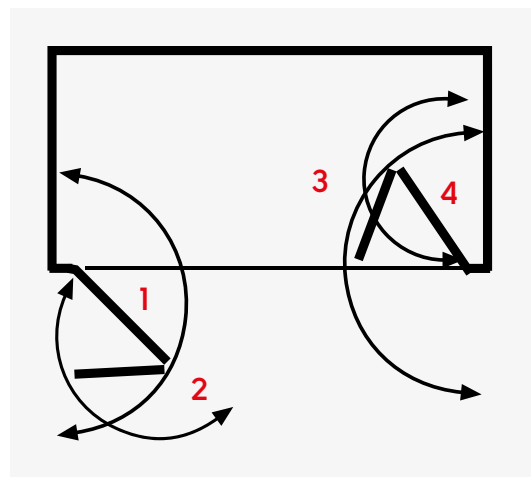





## Glass Shower Screens



- + Compatible with all AKW curbless or low-level shower bases
- + Available with/without pivoting deflector panel for additional flexibility
- + Features strong, tempered safety glass with a coating to reduce cleaning

Modern in design yet incredibly functional, wall-mounted Glass Shower Screens help to prevent water escaping from the shower, reducing the risk of slips and falls in the bathroom.

Available with or without a pivoting deflector panel which further helps with water retention, all screens also come with a watertight, high integrity seal for additional peace of mind.

All screens are made with tempered safety glass that complies with ANSI Z97.1-2009 UA and CPSC 16 CFR 1201 II, and is easy to maintain, with a special coating to help keep it cleaner for longer.

Simple to install, screens are supplied with an end post (available in polished chrome or matte black), wall channel, leveling hardware, and supporting wall brace. For extra stability or larger showers with more than one screen, Tie Bars can be ordered **a la carte** (see "Tie Bars" on page 39).



Glass Shower Screen & Deflector Panel – Polished chrome finish



Glass Shower Screen & Deflector Panel – Matte black finish

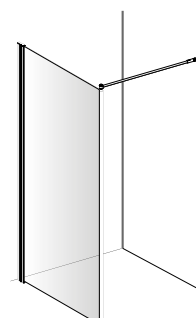

### Glass Shower Screens

Configuration	Product Code	Width	Height	Finish
	LB00215	27 1/2"	76 3/4"	Polished Chrome
	LB00216	31 1/2"	76 3/4"	Polished Chrome
	LB00217	35 1/2"	76 3/4"	Polished Chrome
	LB00218	39 1/2"	76 3/4"	Polished Chrome
	LB00216BK	31 1/2"	76 3/4"	Matte Black
	LB00217BK	35 1/2"	76 3/4"	Matte Black
	LB00218BK	39 1/2"	76 3/4"	Matte Black

### Glass Shower Screens & Deflector Panels

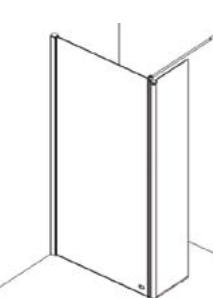
Configuration	Product Code	Panel Width	Screen Width	Height	Finish
	27019	13 3/4"	23 2/3"	74 3/4"	Polished Chrome
	27020	13 3/4"	27 1/2"	74 3/4"	Polished Chrome
	27021	13 3/4"	31 1/2"	74 3/4"	Polished Chrome
	27022	13 3/4"	35 1/2"	74 3/4"	Polished Chrome
	27028	13 3/4"	39 1/2"	74 3/4"	Polished Chrome
	27018BK	15 3/4"	31 1/2"	74 3/4"	Matte Black
	27031BK	15 3/4"	35 1/2"	74 3/4"	Matte Black
	27017BK	15 3/4"	39 1/2"	74 3/4"	Matte Black

### Tie Bars

Product Code	Length	Finish
LB00123	27 1/2"	Chrome
LB00124	31 1/2"	Chrome
LB00125	35 1/2"	Chrome





# 04

## Wall Panels & Decor

43 Velena Wall Panels

49 FastNICHE Shower Niches

**Finishing an accessible bathroom can require a little extra thought, especially if they have specialized care needs.**

Wall panels can help to achieve a superior, stylish finish that's also highly durable, ideal for people using wheelchairs or living with conditions that cause involuntary movements.

Recessing storage into the wall using a shower niche can increase the available floor space, while allowing you to add shelves at an accessible height.

Our range of watertight wall panels and shower niches to see how simple, considered modifications can make a huge difference.



## Velena Wall Panels



- + Choice of contemporary designs and colors for a stylish finish
- + Suitable for fixing shower seats and grab bars to in accessible spaces
- + Lightweight, strong, and extremely hard-wearing alternative to tile

Velena Wall Panels provide a contemporary yet practical wall finish which is especially beneficial for those with disabilities.

Made from the same rigid material as our Tuff Form Shower Bases, the glass-fiber reinforced plastic offers high mechanical strength and an extremely durable, watertight finish with panels easily joined using aluminum trims and sealed with silicone caulk.

Wall panels are incredibly simple to install, with large sections of the wall able to be covered quicker than traditional tiles. Due to the panels size, they benefit from minimal joints, which reduce the risk of leaks while also eliminating the need for grout, which can be very difficult for people with disabilities to clean and maintain.

Mobility accessories such as shower seats and grab bars can be easily fixed to walls covered with Velena Wall Panels without causing damage to the surface finish.

The added durability of the panels means they are ideal for use in bathrooms with a higher care need. For instance, some people may require additional help when showering, during which they may potentially strike the walls due to involuntary movements. Unlike other wall finishes which could become damaged by single or repeated impacts, Velena Wall Panels are designed to withstand this type of use, making them ideal for installation in accessible bathrooms.

Velena Wall Panels are available in 3 modern designs – Hexagon, Subway, and Large Format Tile – with the patterns intended to mimic the aesthetic of tile, while offering the additional benefits of glass-fiber reinforced plastic. Panels are 84" high as standard, with 96" panels available upon request through our team, and offered in 36", 48" and 60" widths, with 2 colors to choose from – cool white or dark gray.

Velena Wall Panels and our range of aluminum trims can be ordered a la carte, or purchased in a handy kit which is designed to cover an entire showering area.

For a complete accessible bathroom, see our selection of complementary Velena Shower Seats ([see page 9](#)).

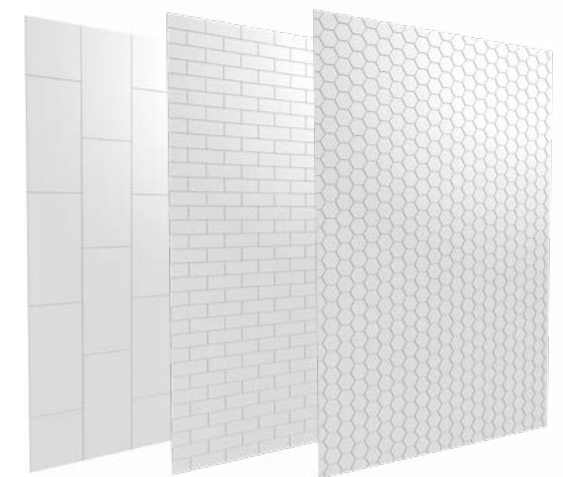



## Size/Design Options & Product Codes

Velena Wall Panels are available in 3 designs, with 3 widths to choose from if ordering a la carte – 36", 48" and 60". Velena Wall Panel Kits are designed to cover an entire showering area, with various sizes available to suit your installation. Large Format Tile is available in white or gray, with Subway Tile and Hexagon Tile designs offered in white only.

### Wall Panel Kits

Product Name	Product Code
Velena Wall Panels Subway Tile Pattern Kit (48x36x84")	27815WH
Velena Wall Panels Subway Tile Pattern Kit (60x36x84")	27816WH
Velena Wall Panels Hexagon Tile Pattern Kit (48x36x84")	27821WH
Velena Wall Panels Hexagon Tile Pattern Kit (60x36x84")	27822WH
Velena Wall Panels Large Format Tile Pattern Kit (48x36x84")	27818WH
Velena Wall Panels Large Format Tile Pattern Kit (60x36x84")	27819WH
Velena Wall Panels Large Format Tile Pattern Kit (48x36x84")	27818GR
Velena Wall Panels Large Format Tile Pattern Kit (60x36x84")	27819GR

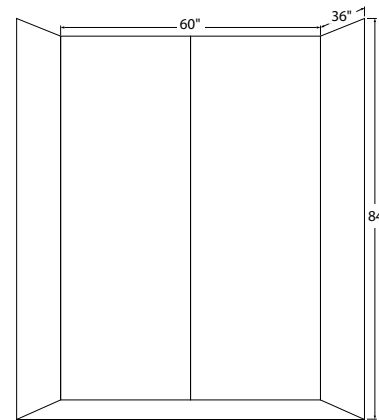
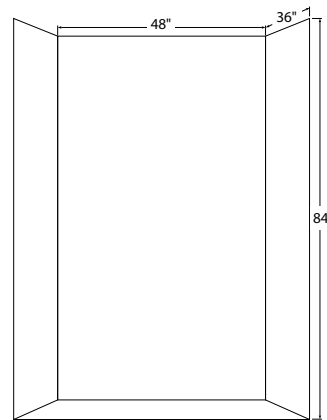

#### 48" Kits include:

- + 1 x Velena Wall Panel 48" x 84"
- + 2 x Velena Wall Panels 36" x 84"
- + 2 x Velena Wall Panels 84" Internal Corner
- + 6 x Velena Wall Panels 84" End Cap
- + 8 x 10 oz. tubes Tank/10 Polyurethane Construction Adhesive
- + 2 x 10 oz. tubes silicone caulk

#### 60" Kits include:

- + 2 x Velena Wall Panels 30" x 84"
- + 2 x Velena Wall Panels 36" x 84"
- + 1 x Velena Wall Panels 84" H-Section
- + 2 x Velena Wall Panels 84" Internal Corner
- + 6 x Velena Wall Panels 84" End Cap
- + 8 x 10 oz. tubes Tank/10 Polyurethane Construction Adhesive
- + 2 x 10 oz. tubes silicone caulk

### Wall Panels (A La Carte)

Product Name	Product Code
Velena Wall Panel Subway Tile Pattern 36" x 84" – White	27803WH
Velena Wall Panel Subway Tile Pattern 48" x 84" – White	27804WH
Velena Wall Panel Subway Tile Pattern 60" x 84" – White	27805WH
Velena Wall Panel Hexagon Tile Pattern 36" x 84" – White	27809WH
Velena Wall Panel Hexagon Tile Pattern 48" x 84" – White	27810WH
Velena Wall Panel Hexagon Tile Pattern 60" x 84" – White	27811WH
Velena Wall Panel Large Format Tile Pattern 36" x 84" – White	27806WH
Velena Wall Panel Large Format Tile Pattern 36" x 84" – Gray	27806GR
Velena Wall Panel Large Format Tile Pattern 48" x 84" – White	27807WH
Velena Wall Panel Large Format Tile Pattern 48" x 84" – Gray	27807GR
Velena Wall Panel Large Format Tile Pattern 60" x 84" – White	27808WH
Velena Wall Panel Large Format Tile Pattern 60" x 84" – Gray	27808GR

\*96" high panels available by special order

### Wall Panel Trims (A La Carte)

Product Name	Product Code
Velena Wall Panels 84" End Cap – Satin Silver (Aluminum)	27814
Velena Wall Panels 84" H-Section – Satin Silver (Aluminum)	27813
Velena Wall Panels 84" Internal Corner – Satin Silver (Aluminum)	27812
Velena Wall Panels 84" External Corner – Satin Silver (Aluminum)	27824

#### Trim Options (84")

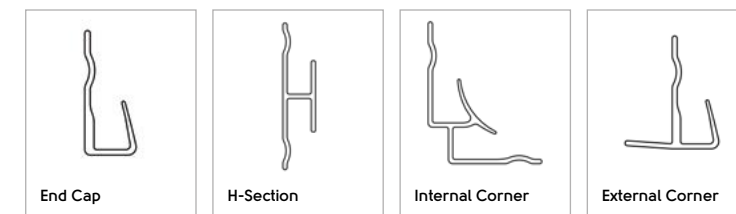



Subway Tile

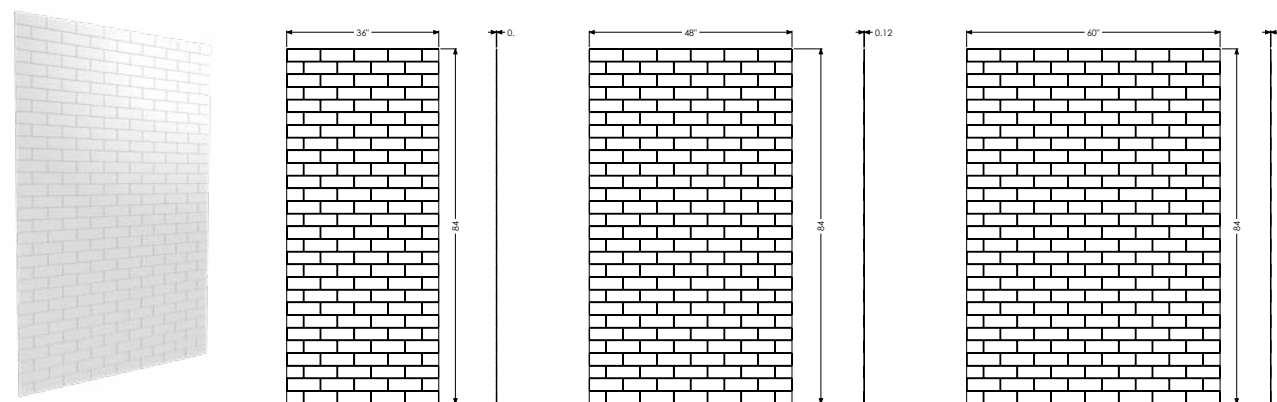

Hexagon Tile

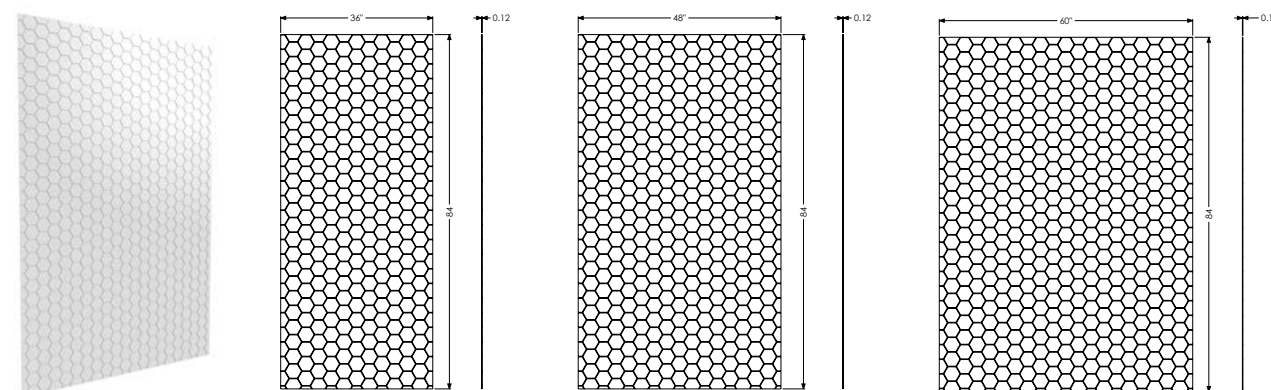

Large Format Tile

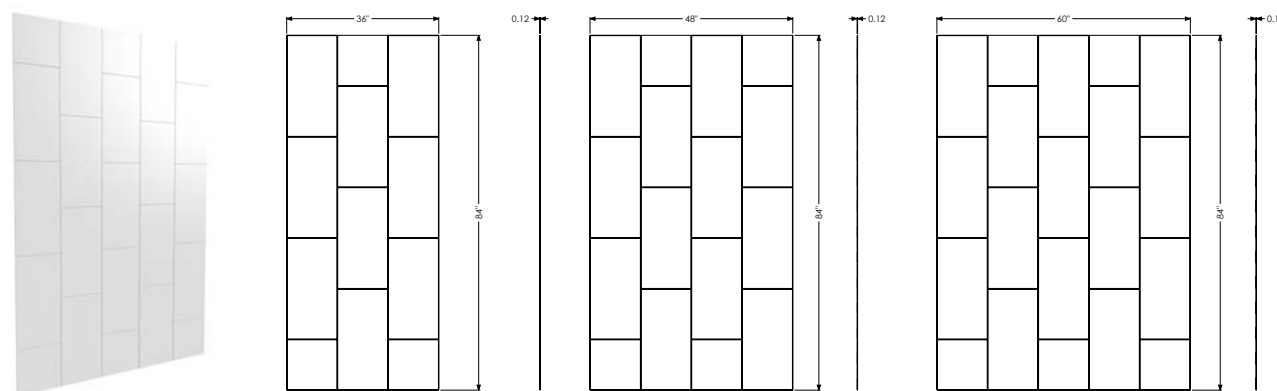





FastNICHE Shower Niche – Triple

## FastNICHE Shower Niches



- + Simple way to create extra bathroom storage space
- + Just recess into the wall, adhere, and seal for a lasting finish
- + Durable composite materials ideal for accessible bathrooms

FastNICHE Shower Niches are the simple yet effective way to create extra storage in a bathroom. This is especially beneficial in accessible bathrooms as they allow you to reduce clutter and maximize the available floor space, which is ideal for people using wheelchairs or those unsteady on their feet.

Complete with a lifetime warranty, our shower niches are made from sheet-molded compound glass-fiber reinforced plastic (GRP) for increased durability. Available in 3 sizes - double, triple or full - with all sizes offered in a glossy white finish; full-sized niches also come in bold matte black for a highly contemporary look.

Double and triple niches can be installed at any height to make them more accessible for people using shower seats ([see page 07](#)), full-sized niches can also be trimmed down to size if required.

Supplied in one structural piece between 3 1/2"-3 3/4" deep, shower niches are quick and easy to install. They simply slot into a recess in the wall and are fixed with adhesive, before being sealed with silicone caulk ([available a la carte](#)). They're also pre-finished, so you don't need to cover them with tile or wall panels.

Pair FastNICHE Shower Niches with our collection of Velena Wall Panels ([see page 43](#)), or install alongside tile or stone.



## Size Options & Product Codes

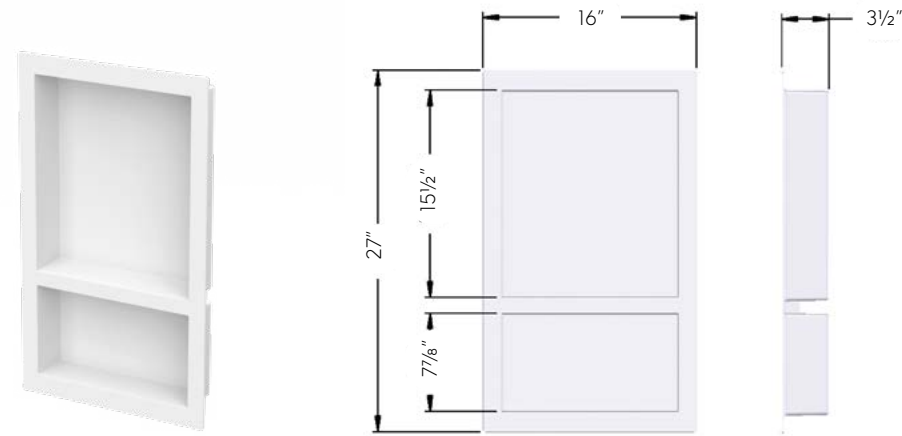

### FastNICHE Shower Niche – Double

White: 27802-WH

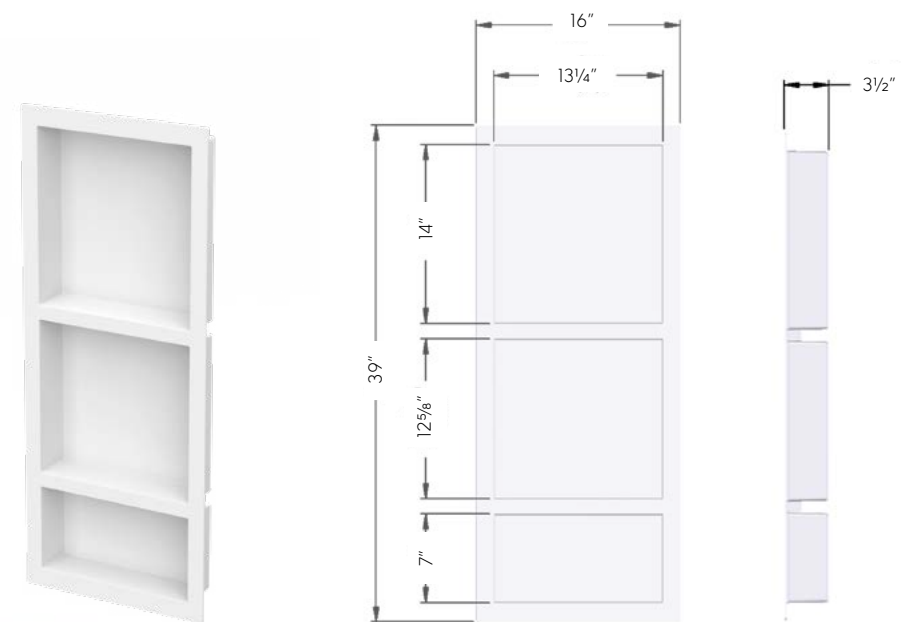

### FastNICHE Shower Niche – Triple

White: 27801-WH

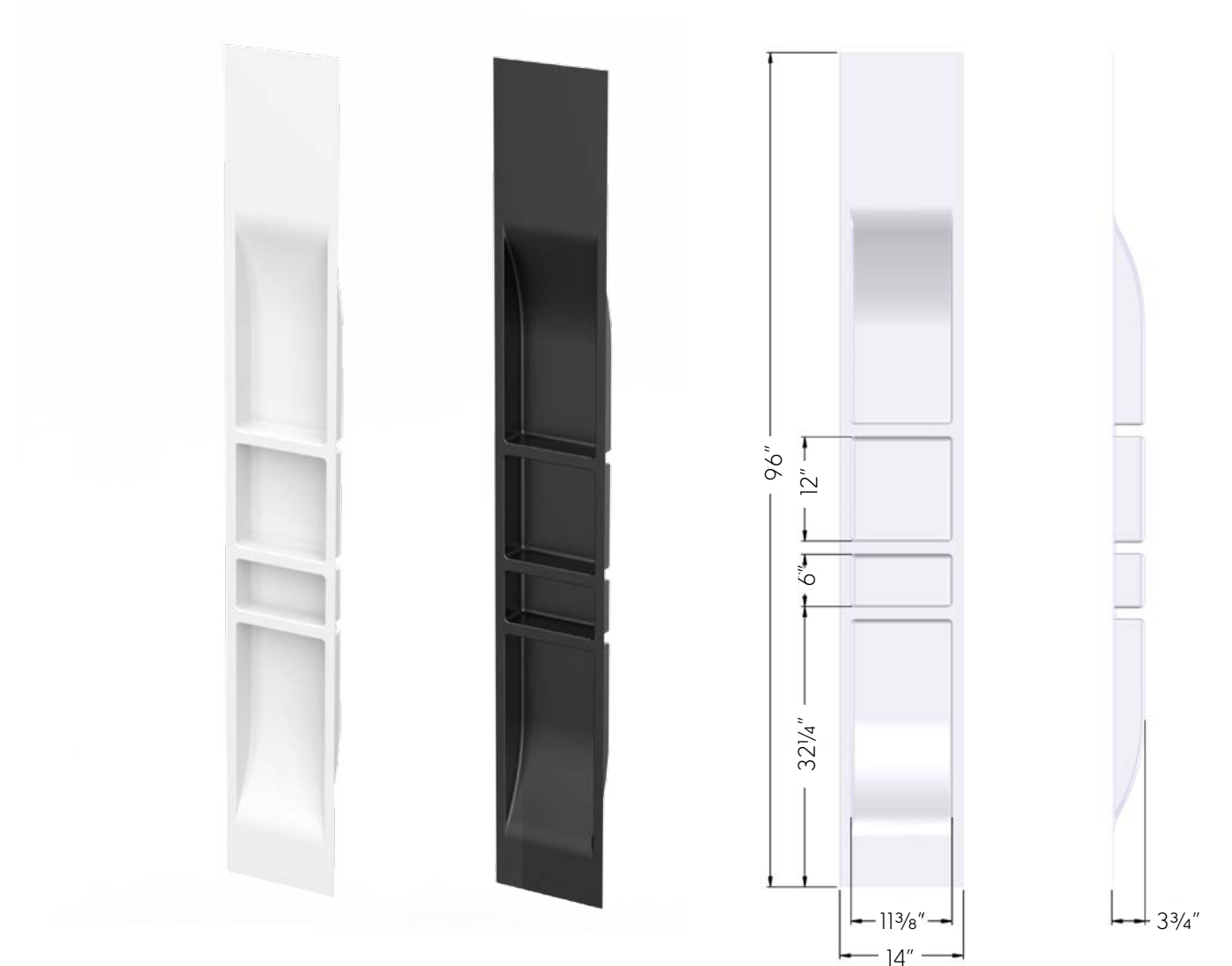

### FastNICHE Shower Niche – Full

White: 27800-WH

Black: 27800-BK





# 05

## Curbless & Low-Level Shower Bases

- 54 Installing Curbless Shower Bases
- 57 FastDEK Shower Bases
- 61 FastDEK Linear Shower Bases
- 63 FastDEK Installation Accessories
- 65 Tuff Form Shower Bases
- 69 Tuff Form8 Shower Bases
- 73 Tuff Form Drains
- 77 Tuff Form Ultimate Linear Shower Base
- 79 Tuff Form Linear Tub Replacement Shower Base
- 81 TriForm Shower Bases
- 83 TriForm Drains
- 85 Pitch Extension Panels
- 87 Waterproofing Kits



# Installing Curbless Shower Bases

Curbless showering is rightly becoming the new standard in bathroom design as it increases accessibility and safety for all. Luckily for you, we're the experts in barrier-free showering with Tuff Form shower bases being sold worldwide for over 25 years.

We know from experience that creating a zero-entry shower couldn't be simpler. Our range of curbless bases are tried, tested and trusted by contractors all over the globe, and can be installed in 4 quick and easy steps.

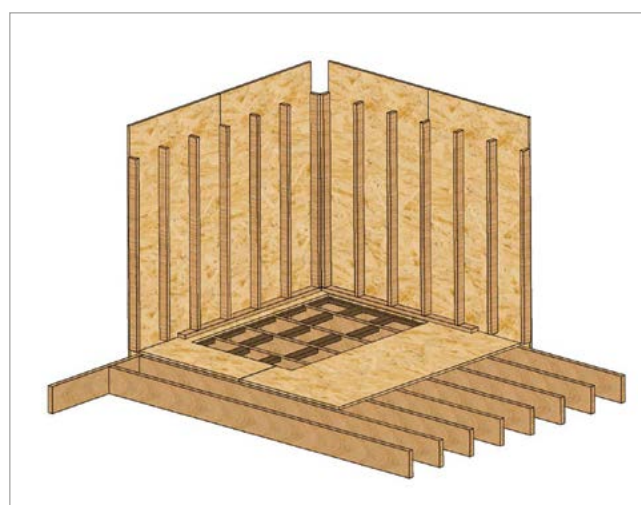

## 1 - Remove subfloor and add blocking

Our wide range of pre-sloped shower bases are thin yet incredibly strong and designed to be very easy to install.

Once the sub-floor has been removed, simply add blocking around the perimeter and around the drain for support - you do not need to cut into any joists.

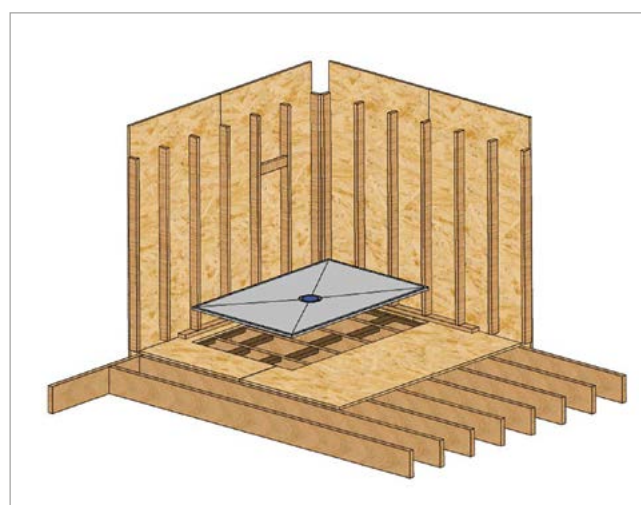

## 2 - Install shower base

Install the base directly onto the joist and into a bed of Tank/10 Construction Adhesive, ensuring this is level with the surrounding floor.

Tuff Form shower bases come with a flat perimeter and pre-drilled, countersunk pilot holes which allow you to secure the base to the joist using the screws provided.

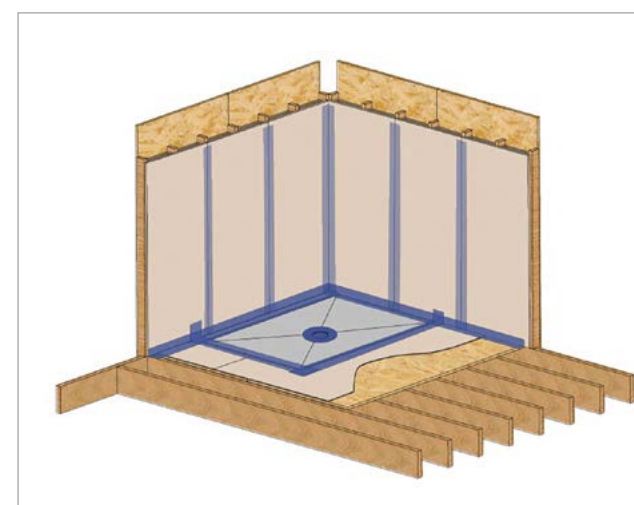

## 3 - Connect drain and seal joints

Plumb in the drain most suited to your shower base and connect this to the drain line.

Seal all joints around the outside of the base and along the walls using joint reinforcement tape, a drain gasket (for Tuff Form & TriForm products), and Tank/10 Waterproofing Compound. These materials are available a la carte or supplied in our Waterproofing Kits ([see page 87](#)) and FastDEK Installation Kit ([see page 63](#)).

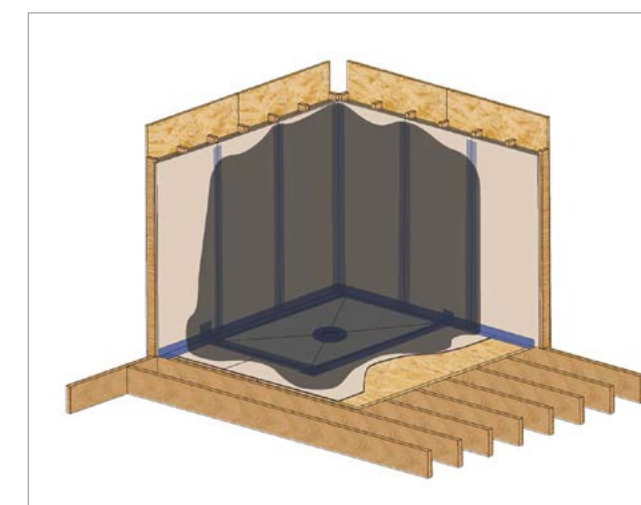

## 4 - Complete waterproofing

For tile-over enclosures, cover the entire shower in two coats of Tank/10 Waterproofing Compound ([see page 87](#)) once the seams are sealed, to ensure your installation is completely watertight.

When the area is dry and fully cured, you're free to install wall panels, tile, stone and/or commercial-grade vinyl flooring in the shower.





## FastDEK Shower Bases



- + Available in 3 contemporary colors
- + Textured stone-effect finish helps with drainage and slip resistance
- + Incredibly lightweight (less than 55lbs) but exceptionally strong

Made from durable compression molded glass-fiber reinforced plastic (GRP), the underside of FastDEK bases features a grid design for greater strength – supports up to 440lbs – while also being lightweight, making installation quick and easy.

Available in cool white, bold black or subtle gray, the textured surface replicates natural stone for improved drainage and slip resistance.

Install above the floor or directly onto joists for curbless, zero-entry access – ideal for those with health or mobility issues. 1" high ramps are available for above floor, wheelchair accessible showers (see page 63).

We highly recommend the FastDEK installation kit (see page 63); this includes a PVC drain coupling for leak-proof connection to a 2" drain line, which is hidden beneath the surface and color-matched cover (supplied with base).

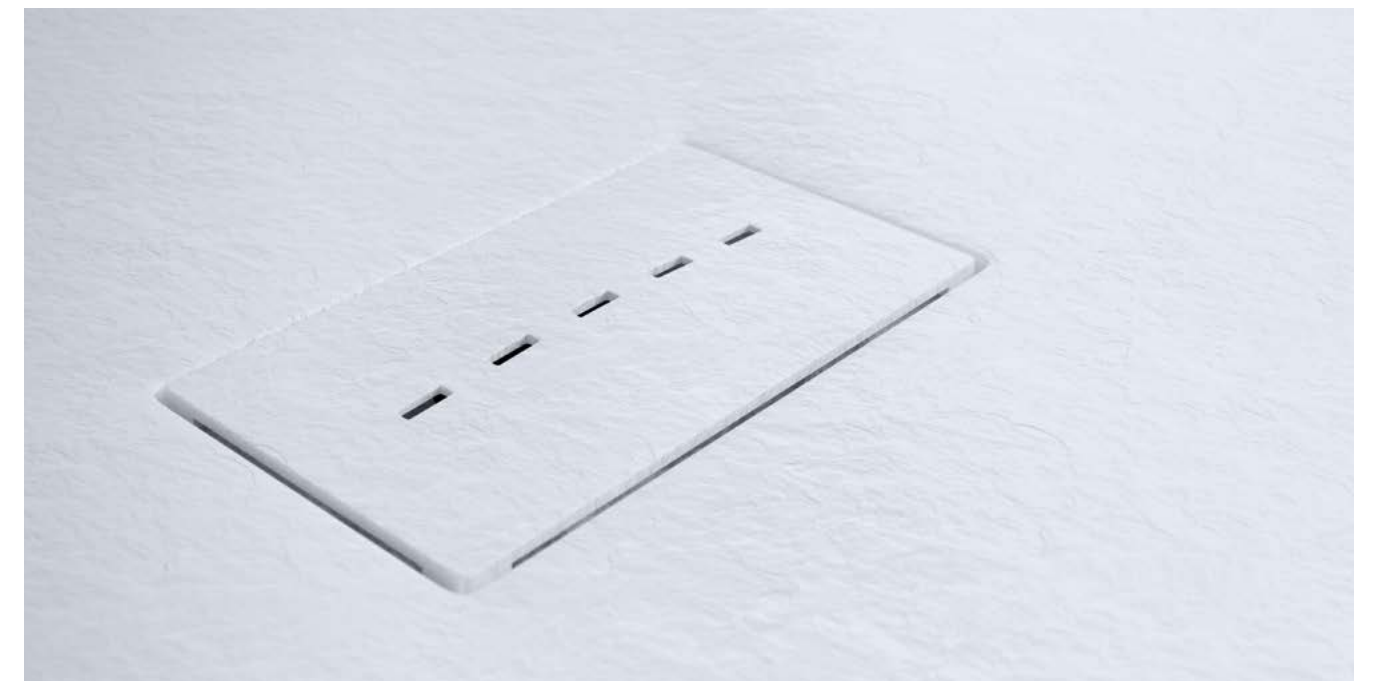
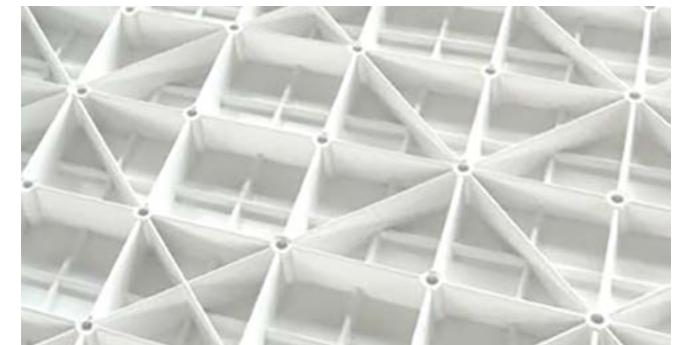

## Size Options & Product Codes

FastDEK shower bases are available in 9 sizes with almost all options offered in a choice of cool white, bold black or subtle gray.

Please note, **FastDEK shower bases cannot be cut** and doing so would void any manufacturer warranty offered.

### FastDEK Shower Base - 47 1/4" x 31 1/2"

White: 11853 Perimeter: 1" thick  
 Black: 11854  
 Gray: 11876

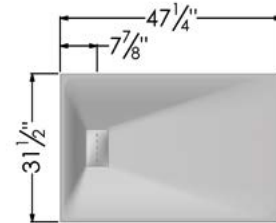

### FastDEK Shower Base - 47 1/4" x 35 1/2"

White: 11855 Perimeter: 1" thick  
 Black: 11856  
 Gray: 11877

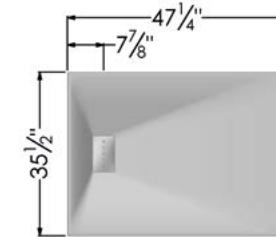

### FastDEK Shower Base - 59" x 31 1/2"

White: XXXXXWH Perimeter: 1" thick  
 Optional stainless-steel grid drain cover **available a la carte**.

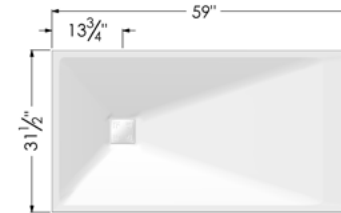

### FastDEK Shower Base - 59" x 35 1/2"

White: 12839WH Perimeter: 1" thick  
 Optional stainless-steel grid drain cover **available a la carte**.

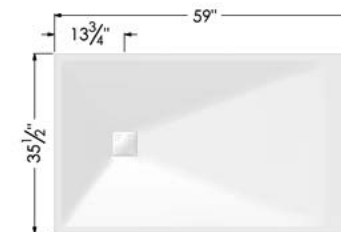

### FastDEK Shower Base - 63" x 31 1/2"

White: 11857 Perimeter: 1" thick  
 Black: 11858  
 Gray: 11880

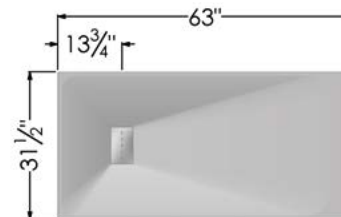

### FastDEK Shower Base - 63" x 35 1/2"

White: 11859 Perimeter: 1" thick  
 Black: 11860  
 Gray: 11881

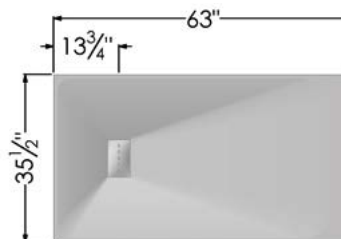

### FastDEK Shower Base - 71" x 31 1/2"

White: 11865 Perimeter: 1" thick  
 Black: 11866  
 Gray: 11884

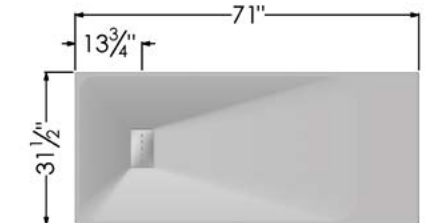

### FastDEK Shower Base - 71" x 35 1/2"

White: 11867 Perimeter: 1" thick  
 Black: 11868  
 Gray: 11885

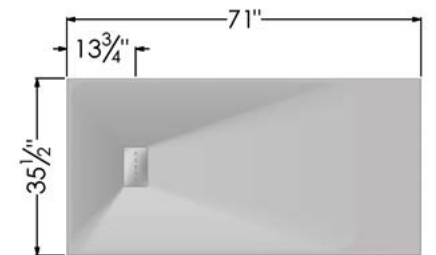

### FastDEK Shower Base - 78 3/4" x 39 3/8"

White: 11894 Perimeter: 1" thick

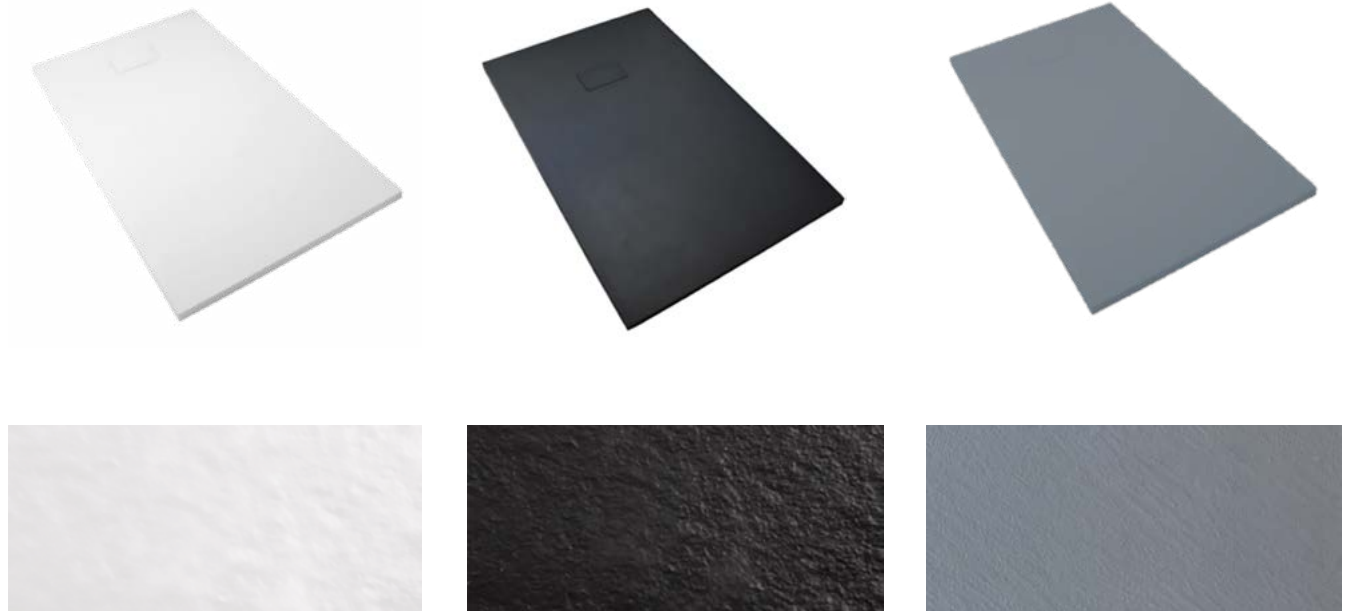
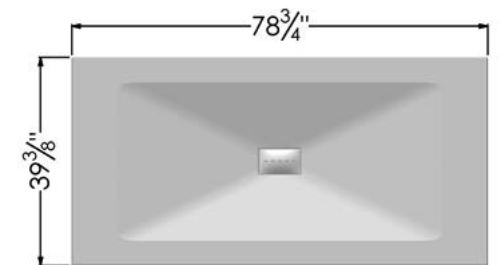





# FastDEK Linear Shower Bases



- + Stylish central linear drain cover included
- + Durable materials to support 546lb max. capacity
- + Stone-effect finish for superior slip resistance

With a central drain hidden by a stainless-steel linear cover (included), FastDEK Linear combines superior strength – maximum capacity of 550lbs – with contemporary styling.

Made from pre-sloped, compression molded glass-fiber reinforced plastic (GRP), the stone-effect white finish is not only beautiful but practical as it provides excellent slip resistance.

FastDEK Linear is available in 3 sizes and is only 1" thick around the perimeter; please note, **bases cannot be cut** and doing so voids the manufacturer warranty.

Bases can be installed above the floor or directly onto joists for curbless, zero-entry - ideal for those with health or mobility issues. 1" high ramps are available for above floor installations requiring wheelchair access (**see page 63**).

For fast and simple installation, we highly recommend using FastDEK installation kits (**see page 63**).

## FastDEK Linear Shower Base - 47 1/4" x 35 1/2"

23964-WH

Perimeter: 1" thick

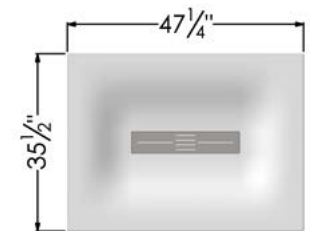

## FastDEK Linear Shower Base - 59" x 35 1/2"

23977-WH

Perimeter: 1" thick

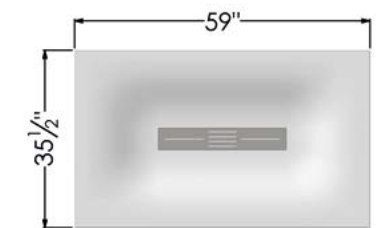

## FastDEK Linear Shower Base - 71" x 35 1/2"

23975-WH

Perimeter: 1" thick

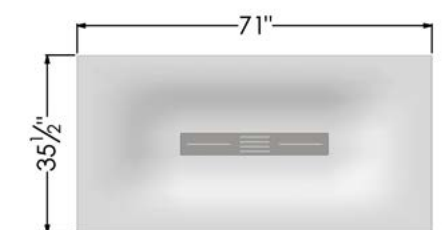





## FastDEK Installation Accessories

### FastDEK Ramps

Ensuring wheelchair access for bases installed above the floor and measuring 47 1/4" (length) x 4 1/3" (width) x 1" (height), FastDEK Ramps can be cut to fit and screw to the floor with pre-drilled, countersunk pilot holes.

For corner showers, corners are available to bridge the gap between ramps.



FastDEK Ramp

12844

### FastDEK Installation Kit

Designed to make installing FastDEK shower bases even easier, our convenient kit includes Tank/10 adhesive which can be used to bond the base to joists or wooden subfloor (modified thin-set mortar may be used to bond to concrete), patented self-adhesive joint reinforcement tape for sealing the perimeter, 1/2 gallon of Tank/10 liquid waterproofing compound to protect the area from leaks, a PVC drain connector, and silicone caulk to provide the final seal once all decorative flooring and wall materials are installed.

All installation and waterproofing supplies are also **available a la carte**, speak to our team for more information.

#### Kit includes:

- + Tank/10 polyurethane construction adhesive (6 x 10 oz. tubes)
- + 100% silicone caulk (2 x 10 oz. tubes)
- + 20' Joint reinforcement tape with adhesive strip along one edge
- + Drain connector x 1
- + Tank/10 liquid waterproofing compound (1/2 gallon – covers approx. 30 sq. ft. with two coats)



FastDEK Ramp Corner

12843



FastDEK Installation Kit

FB2000-IK





## Tuff Form Shower Bases



- + An AKW favourite with over 600,000 sold worldwide!
- + Create a zero-entry shower without modifying joists
- + Simple to install, easy to cut/enlarge and customize

Showers built on Tuff Form bases offer the timeless advantage of zero-entry access which is designed to be wheelchair and disability friendly as well as easier to clean and safer to use - for the whole family, for years to come.

Made from incredibly strong compression molded glass-fiber reinforced plastic (GRP), Tuff Form can support up to 840lbs when installed on wooden joists, more than enough to support a wheelchair user and carer. They can also be cut down, or extended to comply with ADA regulations using our Pitch Extension Panels ([see page 85](#)).

Combine with a Tuff Form Drain ([see page 73](#)) for fast and efficient drainage; these pre-sloped bases have a  $\geq 2\%$  per foot gradient (varies due to length of pitch) which prevents water from pooling or flooding the bathroom.

Installation is simple, with a waffle underside which ensures structural strength while reducing weight, and pre-bored, countersunk pilot holes provided along the perimeter. There's no need to cut into joists, so you can prepare the shower for waterproofing in hardly any time at all; it even works with underfloor heating.

Designed for superior durability, Tuff Form benefits from a limited lifetime warranty and can be refreshed in the future, allowing you to remove flooring, redo any waterproofing ([see page 87](#)), and re-cover without damaging the base.

For over 25 years, installers have tried, tested, and trusted Tuff Form across the US, Canada and Europe, why not ask our team why it's a favorite worldwide.

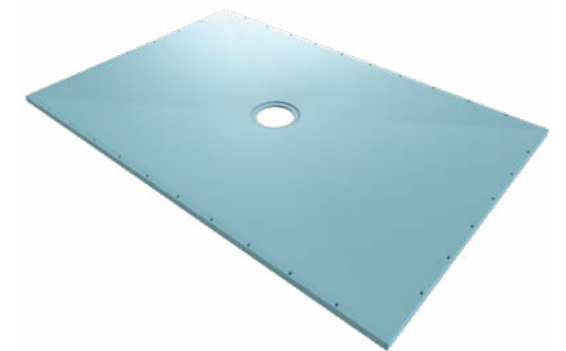

## Size Options & Product Codes

Tuff Form bases are available in 12 sizes with all bases able to be customized by cutting down, or increasing the pitch using our Pitch Extension Panels ([see page 85](#)).

### Tuff Form - 16" x 16"

21001 Perimeter: 7/8" thick

Small yet mighty, this mini Tuff Form base is ideal for installation underneath refrigerators, washing machines or in laundry rooms, and is compatible with all our Tuff Form Drains ([see page 73](#)).

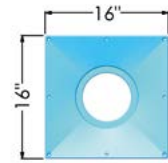

### Tuff Form - 35 1/2" x 35 1/2"

21000 Perimeter: 7/8" thick

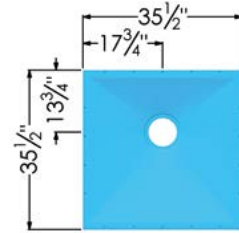

### Tuff Form - 39 3/8" x 39 3/8"

21008 Perimeter: 7/8" thick

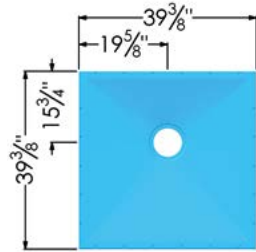

### Tuff Form - 44 3/4" x 30 1/4"

21012 Perimeter: 7/8" thick

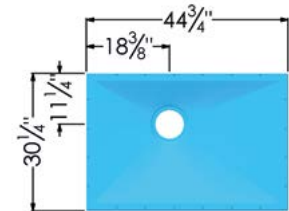

### Tuff Form - 47 1/4" x 47 1/4"

21018 Perimeter: 7/8" thick

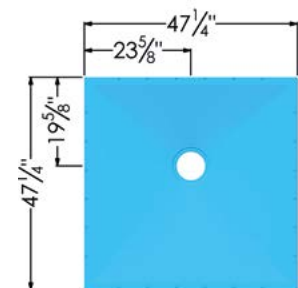

### Tuff Form - 51 1/4" x 32 1/4"

21027 Perimeter: 7/8" thick

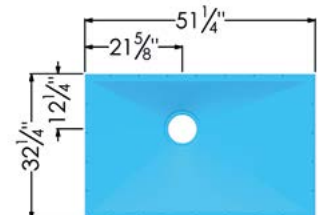

### Tuff Form - 55 1/8" x 35 1/2"

21028 Perimeter: 7/8" thick

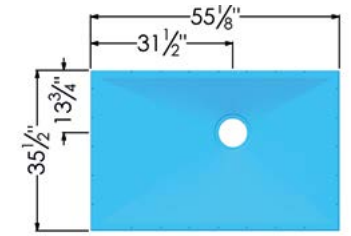

### Tuff Form - 59" x 32 1/4"

21036 Perimeter: 7/8" thick

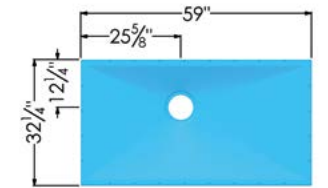

### Tuff Form - 59" x 47 1/4"

21045 Perimeter: 7/8" thick

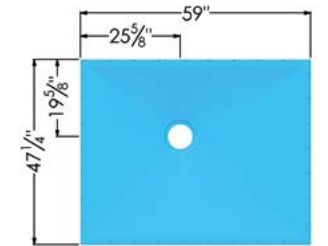

### Tuff Form - 60" x 36"

21035 Perimeter: 1" thick

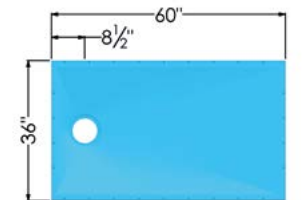

### Tuff Form - 70 7/8" x 32 1/4"

21050 Perimeter: 7/8" thick

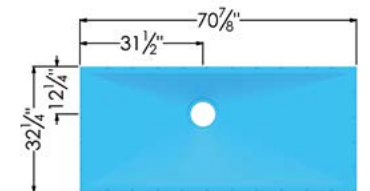

### Tuff Form - 72" x 48"

21053 Perimeter: 1" thick

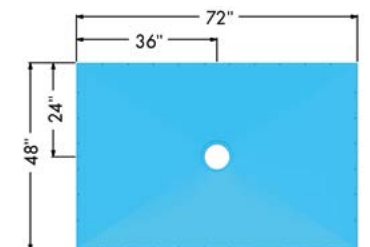





## Tuff Form8 Shower Bases



- + Pre-sloped for quick, efficient drainage
- + Rotating drain plate offers up to 15\* different positions to avoid obstructions
- + Create a zero-entry shower without modifying joists

Tuff Form8 shower bases are a fast and safe way to create a zero-entry shower, without modifying joists.

The unique rotating drain plate enables you to easily change the drain position to avoid joists or obstructions beneath the floor. As shown opposite, each 45° turn of the octagonal plate moves the center of the drain, helping you to achieve up to 15\* different positions, so you can get the best drain position for your installation.

Made from compression molded glass-fiber reinforced plastic (GRP), Tuff Form8 shares the same durable strength, structural properties, and installation characteristics as our Tuff Form shower bases.

These shared benefits include a maximum capacity of 840lbs when supported by wooden joists, making them an ideal choice for wheelchair accessible bathrooms, and the pre-sloped  $\geq 2\%$  per foot gradient (varies due to length of pitch) for quick and efficient drainage.

Tuff Form8 can be trimmed down, or extended using our Pitch Extension Panels to comply with ADA regulations (see page 85). Plumb in a Tuff Form Drain (see page 73) and waterproof (see page 87) before finishing with tile, stone or weldable vinyl.

*\*Rotate drain plate by 45° for 8 different drain positions, 7 further positions achieved by rotating base by 180° due to off-center drain plate.*

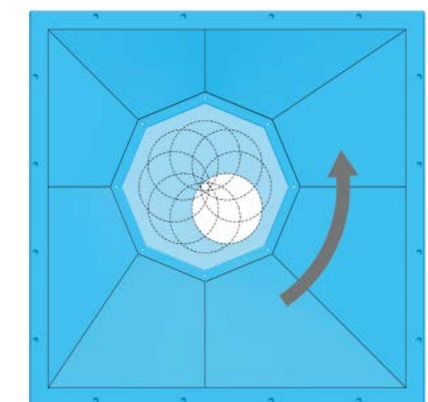
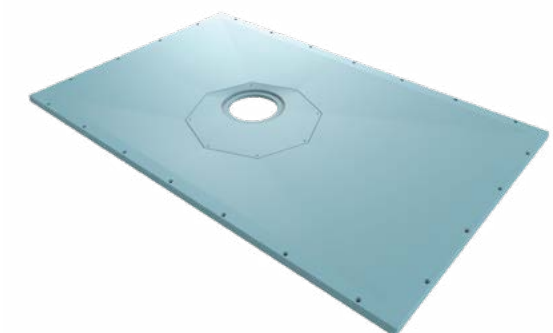
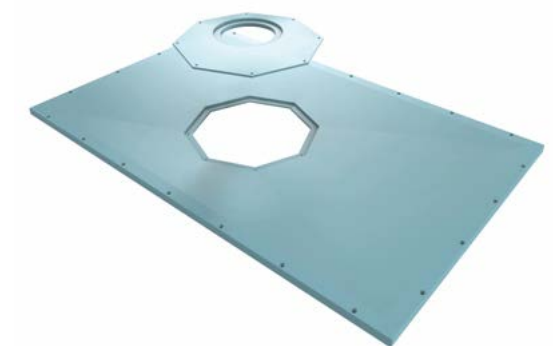

## Size Options & Product Codes

Tuff Form8 bases are available in 9 sizes, with all bases able to be customized by cutting down, or increasing the pitch using our Pitch Extension Panels ([see page 85](#)).

### Tuff Form8 - 35 1/2" x 35 1/2"

21130

Perimeter: 7/8" thick

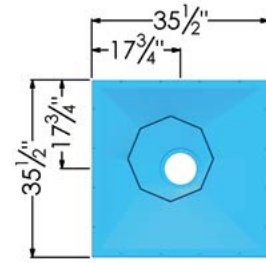

### Tuff Form8 - 39 3/8" x 39 3/8"

21131

Perimeter: 7/8" thick

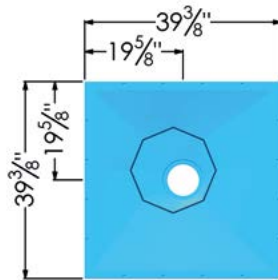

### Tuff Form8 - 44 3/4" x 30 1/4"

21132

Perimeter: 7/8" thick

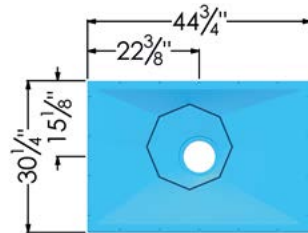

### Tuff Form8 - 47 1/4" x 47 1/4"

21133

Perimeter: 7/8" thick

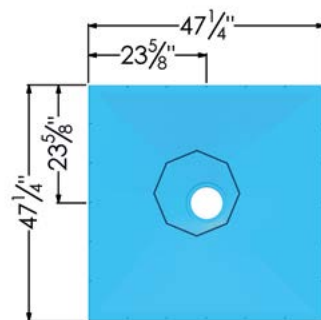

### Tuff Form8 - 51 1/4" x 32 1/4"

21134

Perimeter: 7/8" thick

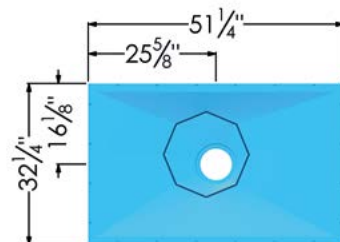

### Tuff Form8 - 55 1/8" x 35 1/2"

21135

Perimeter: 7/8" thick

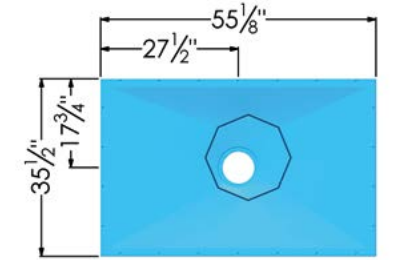

### Tuff Form8 - 59" x 32 1/4"

21136

Perimeter: 7/8" thick

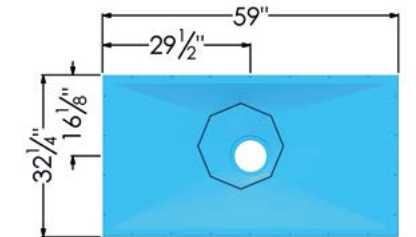

### Tuff Form8 - 59" x 47 1/4"

21137

Perimeter: 7/8" thick

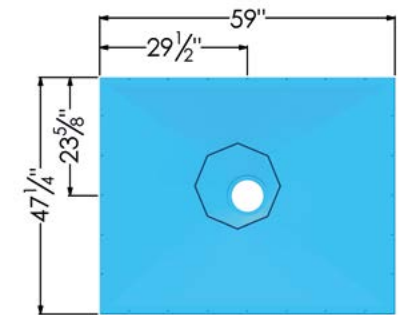

### Tuff Form8 - 70 7/8" x 32 1/4"

21138

Perimeter: 7/8" thick

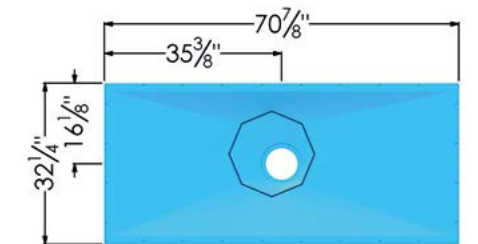





Tuff Form Tile-In Drain

## Tuff Form Drains



- + Styles for both tile and vinyl finished showers
- + Range of grates to choose from, including tile-in option
- + Assemblies supplied with drain connector as standard

Finish your Tuff Form or Tuff Form8 shower with our range of Tuff Form Drains. Available in several stylish colors and decorative patterns, Tuff Form Drains can be installed in bathrooms finished with weldable vinyl or custom tile for a highly contemporary aesthetic.

Drain assemblies include a PVC drain connector for connecting to a 2" drain line (**additional connectors are available a la carte**). Those designed for tiled showers also include a drain gasket which is needed for waterproofing the shower area (**see page 87 for waterproofing supplies**).

Built to last and for easy cleaning and maintenance, all metal assembly parts are made of 304 stainless-steel for superior rust resistance, with black, and oil-rubbed bronze grates benefiting from a hard-wearing color coating for additional durability.

For bathrooms finished with commercial-grade weldable vinyl where there may be a greater care need, the grate is made of strong ABS plastic and designed for regular contact with wheelchairs.

All Tuff Form Drains are compliant with plumbing codes and come with a limited lifetime warranty; all drain connectors are supplied with a 10-year manufacturer warranty.

### Tuff Form Tile-In Drain

Designed to offer a highly contemporary finish, the Tuff Form Tile-In Drain features a durable, square stainless-steel plate which can be filled with decorative tile (between 3/8"-1/2" thick) to match the rest of the shower floor for a 'barely there' look.

- + Drain formed of two simple parts; a square stainless-steel cover and black PVC assembly, making it our easiest drain to install yet!
- + Supplied with drain gasket, stainless-steel screws and 2" Fernco Hub coupling
- + 6-7 gallons per minute maximum flow rate (consult a plumber to calculate needs for a high flow shower)
- + Pre-drilled pilot holes for quick and easy installation



Tuff Form Tile-In Drain

CD1260





**Tuff Form Drain w/ Swirl Grate**  
Brushed Stainless-Steel  
CD1210-BS

### Tuff Form Drains for Tiled Showers

Our range of Tuff Form Drains for tiled showers come with durable stainless-steel grates which are offered in 3 different designs - swirl, pinhole and grid - and up to 4 stylish colors - brushed stainless-steel, polished stainless-steel, oil-rubbed bronze and matte black.

Custom colors are available via special order and come with a 4-week lead time. Please speak to our team for further details and to discuss your requirements.

- + Includes grate, frame, height adjustment collar, lock key, clamping ring, adaptor, drain connector and drain gasket
- + 6-7 gallons per minute maximum flow rate (consult a plumber to calculate needs for a high flow shower)
- + Solvent weld drain connector (supplied) to 2" diameter drain line



**Tuff Form Drain w/ Swirl Grate**  
Polished Stainless-Steel  
CD1290-CH



**Tuff Form Drain w/ Swirl Grate**  
Oil-Rubbed Bronze  
CD1230-ORB



**Tuff Form Drain w/ Swirl Grate**  
Matte Black  
CD1213-BK



**Tuff Form Drain w/ Pinhole Grate**  
Brushed Stainless-Steel  
CD1250-BS



**Tuff Form Drain w/ Pinhole Grate**  
Polished Stainless-Steel  
CD1280-CH



**Tuff Form Drain w/ Pinhole Grate**  
Oil-Rubbed Bronze  
CD1240-ORB



**Tuff Form Drain w/ Pinhole Grate**  
Matte Black  
CD1233-BK



**Tuff Form Drain w/ Grid Grate**  
Oil-Rubbed Bronze  
CD1222-ORB



**Tuff Form Drain w/ Grid Grate**  
Matte Black  
CD1223-BK



**Tuff Form Drain for**  
**Commercial-Grade**  
**Weldable Vinyl**  
CD1250-VL

### Tuff Form Drain for Vinyl Showers

Made from durable ABS plastic with a bright white finish, this drain assembly with circular grate has been designed specifically for use with commercial-grade weldable vinyl flooring.

- + Includes grate, clamping ring, adaptor and drain connector
- + 6-7 gallons per minute maximum flow rate (consult a plumber to calculate needs for a high flow shower)
- + Solvent weld drain connector (supplied) to 2" diameter drain line

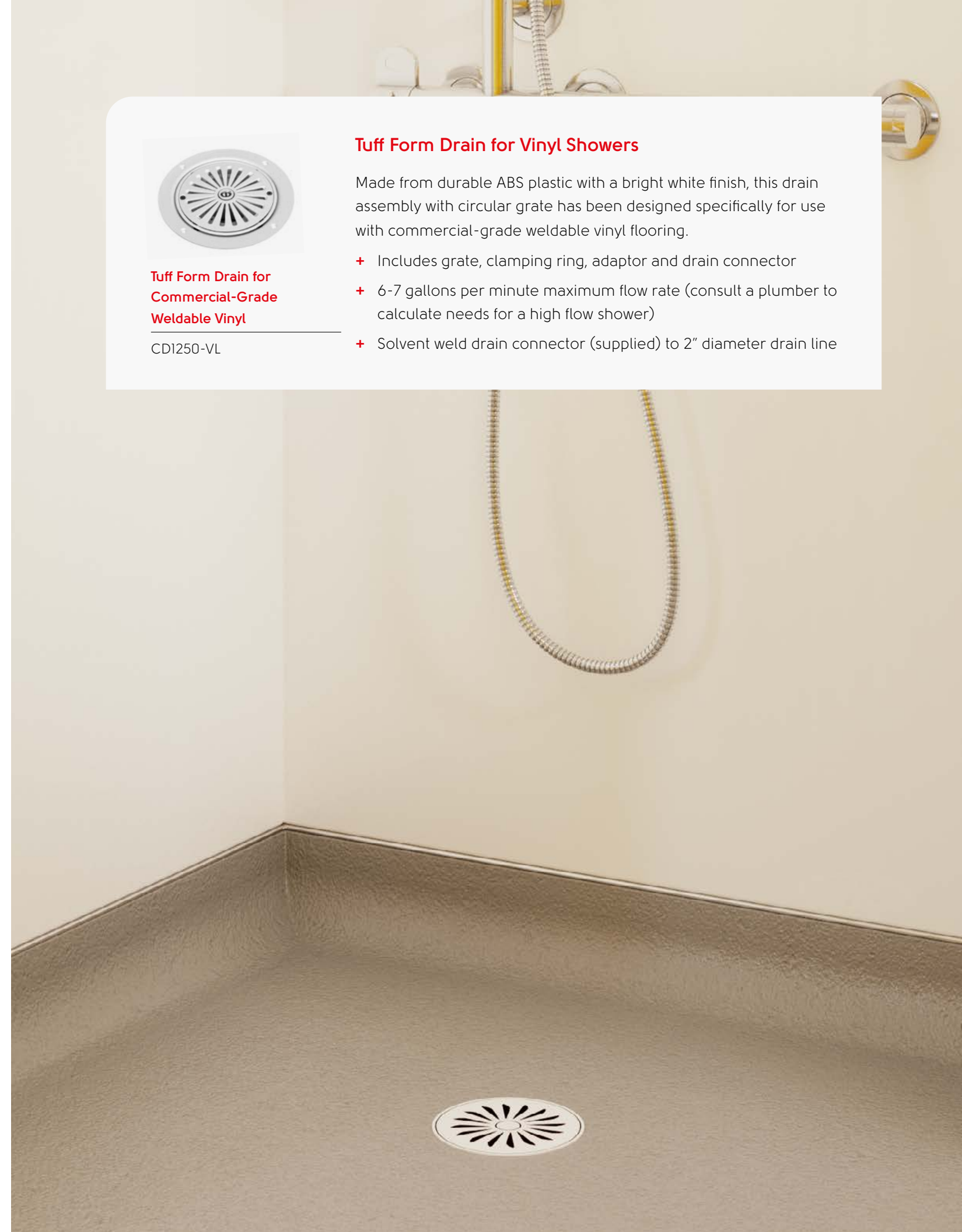





## Tuff Form Ultimate Linear Shower Base



- + Large, single pitch curbless base
- + Create a zero-entry shower without modifying joists
- + Discreet tile-in linear drain included

Constructed from super strong yet lightweight compression molded glass-fiber reinforced plastic (GRP), Tuff Form Ultimate Linear bases can support up to 840lbs and create one large (72" x 48") continuous pitch to the stylish linear drain, enabling safe, zero-entry access to the shower, ideal for those in wheelchairs or living with disabilities.

This curbless base is suitable for use with underfloor heating and can be easily trimmed down on site. You can even install multiple bases to create a bigger shower area if required, with countersunk, pre-bored drill holes along the perimeter for quick installation.

Once fully waterproofed (see page 87), the shower can be beautifully covered with small or large format tile, as can the incredibly discreet stainless-steel linear drain, which runs the full width of the pan for a contemporary, 'barely there' aesthetic that is simple to maintain and keep clean, especially for those with reduced mobility.

Given the reliability of Tuff Form Ultimate Linear, you can replace the tile and redo the waterproofing in the future, without damaging the base structure.

Stainless-steel edge trims are **available a la carte** for open-sided installations, please contact our team to add these to your order.

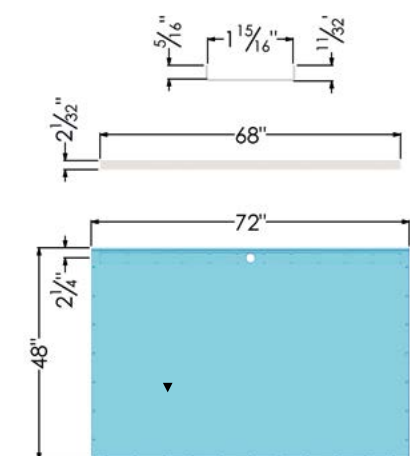
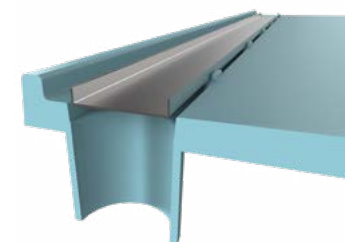
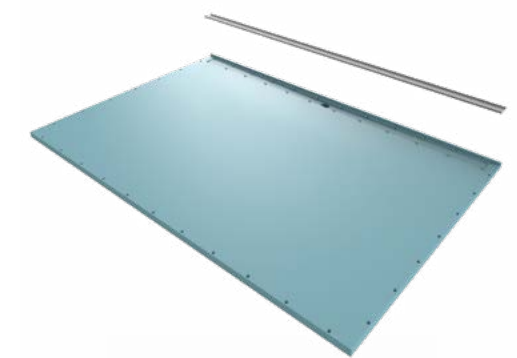

Tuff Form Ultimate Linear Shower Base - 72" x 48"

21240

Perimeter: 1 1/8" thick along deepest side



# Tuff Form Linear Tub Replacement Shower Base



- + Ideal size to replace a bathtub
- + Material can be cut down to size
- + Modern, linear high-flow drain

Our Tuff Form Linear Tub Replacement shower base is the ideal swap for a bathtub that's no longer needed due to reduced mobility and/or health conditions.

Designed for this specific purpose, this base is a hybrid product that combines the stylistic qualities of TriForm shower bases, and the construction materials of our Tuff Form bases – compression molded glass-fiber reinforced plastic (GRP) to offer an increased weight capacity of 840lbs, ideal for supporting a wheelchair and carer.

Incredibly durable and compatible with underfloor heating, the length can be trimmed down (up to 4" from drain) or extended using our Pitch Extension Panels (**see page 85**).

Select from a range of a stylish drains with solid, slotted, or tile-in options to choose from which are available in stainless-steel, oil-rubbed bronze, or matte black finishes.

One drain connector is supplied with the drain cover, with additional connectors **available a la carte**, speak to our team to add more to your order.

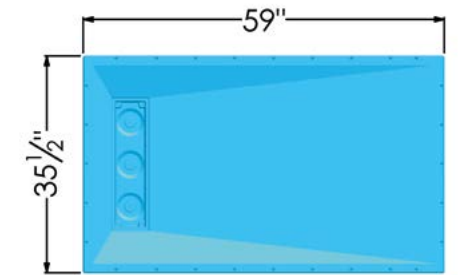

**Tuff Form Linear Tub Replacement Shower Base - 59" x 35 1/2"**

21210

Perimeter: 7/8" thick



To suit 1/4"-5/8" thick tiles



Stainless-Steel Slotted Cover

## Tuff Form Linear Tub Replacement Drain Covers

Product Name	Product Code
Solid Cover – Stainless-steel finish	21211
Solid Cover – Oil-rubbed bronze finish	21211-ORB
Solid Cover – Matte black finish	21211-BK
Slotted Cover – Stainless-steel finish	21228
Slotted Cover – Oil-rubbed bronze finish	21228-ORB
Slotted Cover – Matte black finish	21228-BK





## TriForm Shower Bases



- + Zero-entry showering without modifying joists
- + Choice of contemporary linear drains
- + Effective drainage able to cope with high flow volumes

TriForm shower bases feature a fully integrated drain gulley molded directly into a structural, pre-pitched base that's able to support a maximum capacity of 560lbs.

Precisely sloped to ensure quick, accurate drainage without putting additional demands on the installer, TriForm can be installed directly onto joists to create a curbless shower flush with the bathroom floor - all you have to do is make sure the base is level.

The drain gulley offers up to 3 drain connection points, simply choose the single best location, or install multiple connectors (**available a la carte**) to process higher flow volumes of up to 17 gallons per minute.

Thin yet strong, expensive joist modifications are unnecessary. With a limited lifetime warranty, remodelling in the future is easily achieved, simply remove the existing tile, redo the waterproofing (**see page 87**), and lay new tile without compromising the structural integrity of the base.

TriForm Drains (**see page 83**) have been designed specifically for use with these bases, with a variety of sophisticated stainless-steel or tile-in covers to choose from.

Finish TriForm bases with decorative custom tile – and underfloor heating if needed – for a highly contemporary, curbless showering area that's as stylish as it is safe, especially for those with limited mobility.

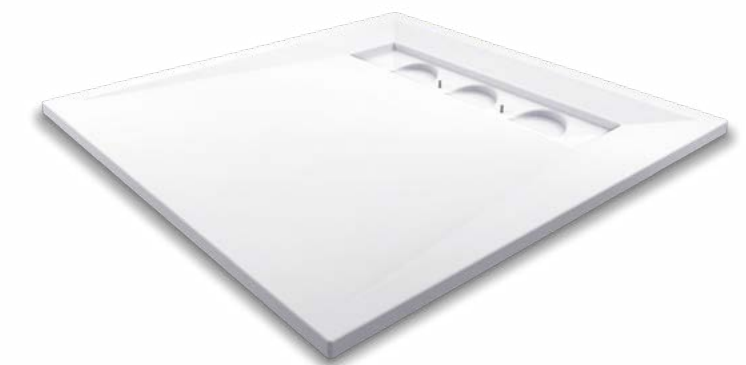
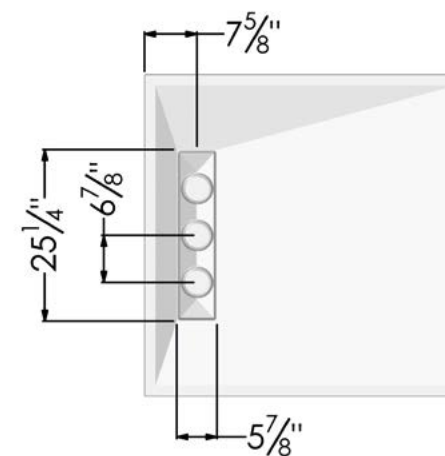

## Size Options & Product Codes

TriForm bases are available in 4 different sizes and **due to their internal structural components, they cannot be cut**, any attempt to do so would void any manufacturer warranty offered. All bases can be customized to increase the length of the pitch using our Pitch Extension Panels (**see page 85**).

### TriForm - 35 1/2" x 35 1/2"

21205

Perimeter: 7/8" thick

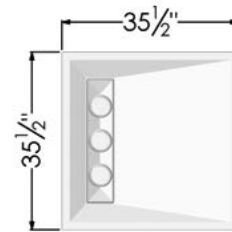

### TriForm - 39 3/8" x 39 3/8"

21206

Perimeter: 7/8" thick

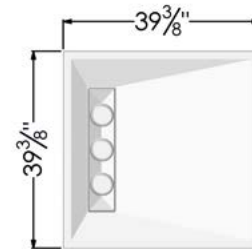

### TriForm - 47 1/4" x 47 1/4"

21208

Perimeter: 7/8" thick

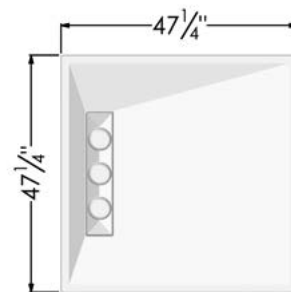

### TriForm - 51 1/4" x 32 1/4"

21207

Perimeter: 7/8" thick

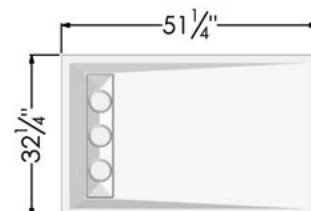

## TriForm Drains



- + Flexible drainage depending on flow requirements
- + Reversible covers for a choice of contemporary looks
- + Available in several durable metal finishes

Designed to complete our range of TriForm shower bases, TriForm Drains can be installed with either a solid or slotted metal cover, or flipped over and finished with custom tile to match the rest of the shower.

Both the solid and slotted drain covers, as well as the tile spacer and adaptor, are constructed of heavy gauge stainless-steel that is available in 3 stylish finishes. For adjustability, hardware is included to fill the cover with decorative tile between 1/4-5/8" thick.

All TriForm drain assemblies come with a drain connector for connection to a 2" drain line. For higher flow showers, order up to 2 additional connectors (**available la carte**).



Reversible Solid Drain Cover  
(Tiled side)



Reversible Solid Drain Cover  
(Stainless-steel side)



Reversible Slotted Drain Cover  
(Stainless-steel side)

### TriForm Drain Covers

Product Name	Product Code
Solid Cover – Stainless-steel finish	21213
Solid Cover – Oil-rubbed bronze finish	21213-ORB
Solid Cover – Matte black finish	21213-BK
Slotted Cover – Stainless-steel finish	21215
Slotted Cover – Oil-rubbed bronze finish	21215-ORB
Slotted Cover – Matte black finish	21215-BK





## Pitch Extension Panels



- + Enlarge your shower base by up an additional 12" per side
- + Compatible with Tuff Form, Tuff Form8, Tuff Form Linear Tub Replacement & TriForm shower bases

Increase the size of most curbless shower bases by an additional 12" per side, enabling you to create an ADA compliant shower, with pre-sloped Pitch Extension Panels.

Measuring 12" x 60" with a 1/4" per foot slope, our extension panels are an ideal substitution for tile backer boards or uncoupling membrane alongside our shower bases.

They're also incredibly useful for creating ADA compliant showers which must have a minimum inside space of 36" x 36" for transfer type showers, or 30" x 60" for roll-in type showers to allow safe wheelchair access. We recommend seeking guidance locally for more information about compliancy and building regulations.

Pitch Extension Panels can be installed as they are alongside shower bases of 7/8" depth, for specialist advice on how to install them with bases of 1" depth, please contact our team who will be happy to support you.

If you're wrapping a corner of a shower base, we recommend keeping the pitch extensions the same width so that mitered corners are symmetrical to give you the best-looking results.

Install pitch extensions on top of the subfloor using ceramic coated cement board screws and Tank/10 polyurethane adhesive (**available a la carte**), or on concrete, using concrete-style, ceramic coated screws and modified thin-set mortar.

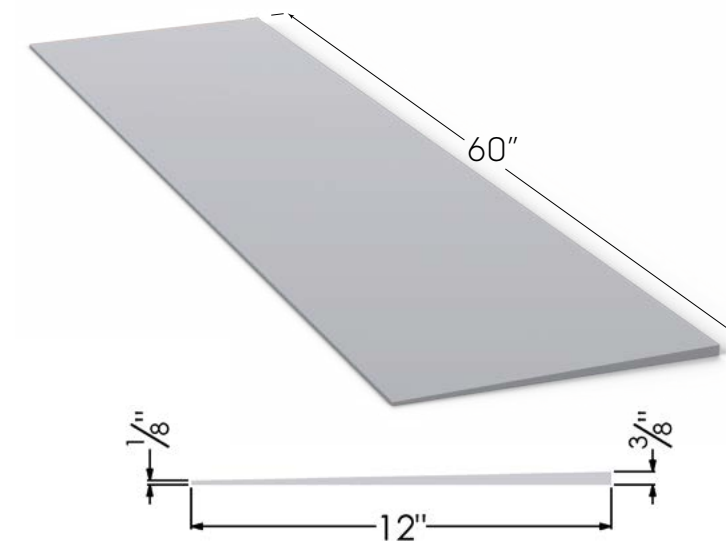

Pitch Extension Panel - 12" x 60"

TB6012-PXT





## Waterproofing & Installation Kits

To help you install and waterproof your shower area, we have a number of reliable products and useful kits available to make the job even easier, with Tank/10 adhesive, paintable caulk, reinforcement tape, pre-formed corners and more.

Our Pro Kit has enough materials to waterproof any AKW shower base, while the Premium Kit includes enough supplies to cover a base plus the walls.

You can also order our waterproofing supplies **a la carte**, speak to our team or review our price list for more details.



### Premium Kit

WPI000-PRE

#### Kit includes:

- + Tank/10 waterproofing compound (2 gallons – covers approx. 120 sq. ft. with two coats)
- + Joint reinforcement tape (3 x 25 ft. rolls)
- + Internal corners x 4
- + External corners x 2
- + Supply gasket x 1
- + Mixer valve gasket x 1
- + #9 x 2½" premium Torx screws x 32
- + Torx bit driver x 1
- + Tank/10 polyurethane construction adhesive (6 x 10 oz. tubes)
- + Painters acrylic latex caulk (1 x 10 oz. tube)
- + Nitrile gloves x 2 pairs
- + Paint roller handle x 1
- + Paint roller covers x 2
- + Paint brush x 1



### Pro Kit

WPI090-PRO

#### Kit includes:

- + Tank/10 waterproofing compound (½ gallon – covers approx. 30 sq. ft. with two coats)
- + Joint reinforcement tape (1 x 25 ft. roll)
- + Internal corners x 2
- + External corners x 2
- + #9 x 2½" premium Torx screws x 32
- + Torx bit driver x 1
- + Tank/10 polyurethane construction adhesive (6 x 10 oz. tubes)
- + Painters acrylic latex caulk (1 x 10 oz. tube)
- + Nitrile gloves x 2 pairs
- + Paint roller handle x 1
- + Paint roller covers x 2
- + Paint brush x 1



# Terms & Conditions

## PLACING ORDERS

Orders may be submitted by email to [orders@akwresourcecenter.com](mailto:orders@akwresourcecenter.com) or by fax to 1-715-743-2738. Orders submitted to AKW Resource Center (AKW) must be on the Buyer's valid purchase order form bearing the company's name, billing address, current email address, and the ship-to address, including a phone number of the recipient (required by carriers for delivery purposes). Orders do not include shipping, handling, or sales tax, which will be added to the Buyer's invoice. Without a valid Reseller's Certificate on file at AKW, sales tax will be added to all invoices when applicable. No orders will be accepted other than in writing. Purchase orders must list the desired AKW item codes and the quantity of each item. AKW will make every reasonable effort to fill all orders, however, we do not guarantee that every product is in stock at the time of an order. We will inform the Buyer of any backordered items and offer the opportunity to cancel or preserve the order. AKW reserves the right to discontinue items and add new items at any time without notice. All shipping weights described, other than those on actual shipping documentation, are approximate and intended solely to assist Buyers with estimating shipping costs. Ground shipping is available to all 48 contiguous US states; please contact us if you require shipping outside of this area.

## CONDITIONS OF SALE

All sales are prepaid by credit card unless the Buyer has an approved credit account with AKW. Terms of credit accounts are established by AKW. Payments on credit accounts must be made with a check, money order, or by ACH transfer. Payment of a credit account with a credit card requires pre-approval and will result in a 4% surcharge. Overdue amounts (that is, any amount not received by the due date shown on the invoice) are subject to a finance charge of 1.5% per month (18% per year). An administrative fee of 50% of the invoice total will be added to any interest charges on any overdue amount when payment is obtained using a collection agency. Returned checks are subject to a \$50.00 fee.

## PRICING

Prices shown in AKW publications are in US dollars. Prices do not include shipping, handling, or sales tax, which will be added to the Buyer's invoice. Without a valid Reseller's Certificate on file at AKW, sales tax will be added to all invoices when applicable. All prices are subject to change without notice. All special offers or discounts are time limited to the month of issuance unless otherwise noted in writing by AKW. AKW makes every effort to display accurate prices, however, in the event that an order is placed for any item priced incorrectly, and the error is discovered prior to shipping the item, AKW reserves the right to correct the inaccuracy or cancel the order. Should this occur, AKW will contact the Buyer, inform the Buyer of the error and provide the actual price of the item, at which time the Buyer will have the option to either confirm the order at the actual price or cancel the order. The price of an item is not final until the item is shipped.

## RETURNS

Returns require pre-approval. Please call AKW to obtain a Return Authorization (RA) form. Returns are subject to a 35% restocking fee. Shipping charges are not refundable. In the event that a return is required, a valid Return Authorization number will be issued. An RA will not be issued more than thirty (30) days after the product's purchase date, except for approved stock rotations and other pre-approved arrangements with authorized AKW distributors. Return Authorizations expire thirty (30) days after the date they are issued, and returns must be received by AKW within that thirty (30) day period, or no credit will be issued. The RA number must be clearly written on the outside of all shipping boxes and pallet wrapping. All merchandise must be returned 100% complete in original packaging with all product parts, packaging material, manuals, and accessories included, and must be in "as new" saleable condition. All products must be returned freight prepaid to AKW. Incomplete or unauthorized returns will be refused. All returned products will be inspected, and, if deemed damaged or used, refunds will not be issued. Items cannot be returned if they were special ordered, made to customer specifications, or are non-inventory or non-stock items.

## TECHNICAL ACCURACY

AKW attempts to be as accurate as possible in describing product specifications, maintenance, usage, care, and installation. AKW does not, however, warrant that product information or other content of any AKW publication or website is accurate, complete, current, or error-free. If a product offered by AKW is not as described, the Buyer's sole remedy is to return it in unused condition for an exchange or refund of the original purchase price. All products must be returned freight prepaid to AKW. Shipping charges are not refundable.

## UPS & SPEE DEE SHIPMENTS

All orders are prepaid and add (PPA), no Freight Collect. Buyers must inspect any shipment upon arrival, and if the package is damaged, refuse the shipment. If the damaged products were shipped to Buyer on AKW's account, the carrier will return the shipment to AKW and we will file a claim and promptly send a new shipment to the Buyer; if the products were shipped to the Buyer on an account other than AKW's, all returns and claims must be processed through that account holder. If the Buyer finds concealed damage, call AKW at once. Again, if the damaged products were shipped on AKW's account, we will instruct the carrier to pick up the package and return it to us for a claim, and we will reship the Buyer's order; if products were shipped on a different account, all returns and claims must be processed through the holder of that shipping account.

## MOTOR FREIGHT SHIPMENTS

Safe delivery of a freight shipment is the responsibility of the carrier. Please examine your shipment carefully before signing the

freight bill. By your acceptance of the shipment from the carrier, affirmed once you sign a freight bill, you acknowledge that the product has been delivered in good condition, relieving AKW and the carrier from further responsibility. If damage is discovered, or if the number of pieces received does not match the number on the freight bill, do not accept the shipment without noting the shortage or damage on the freight bill and insist that the carrier's agent (the driver) sign and date the freight bill near the notation. Failure to complete these steps may jeopardize recovery of the goods or reimbursement for them and relieve the carrier and AKW from all responsibility. If any concealed damage or shortage is discovered while unpacking, leave the material and the packing as is and ask the carrier for a concealed damage or shortage inspection. Consult the carrier for the necessary claim form. When checking shipments, compare what was received with quantities listed on the packing list or invoice. If the carrier leaves the facility before you find a shortage or damage, contact AKW immediately—claims with motor freight companies must be made promptly. You must contact AKW within three (3) business days after receipt of a shipment to report any issues. AKW is not responsible for shortages or damage to goods that are not reported within three (3) business days after receipt of a shipment. Claims for loss or damaged material and transportation charges may not be deducted from any AKW invoice and the payment of AKW invoices must not be withheld awaiting adjustment of such claims since it is the function of the carrier to guarantee safe delivery and to remedy shortage or damage claims.

## COPYRIGHT AND TRADEMARKS

All content, such as text, graphics, logos, icons, images, video and audio clips, digital downloads, and data included in AKW catalogs, brochures, flyers, websites, videos, and other branded materials is the property of AKW or a manufacturer of products sold by AKW, and is protected by international copyright laws. The use of such content is prohibited without the express written consent of AKW.

## WARRANTIES AND LIABILITY

All manufacturer warranties are detailed on AKW's website: [www.akwresourcecenter.com](http://www.akwresourcecenter.com). AKW makes these warranties available, without recourse to AKW to the extent permissible, to authorized distributors and dealers, and extends such warranties to the first retail purchaser who puts a product into service after purchasing it from an authorized distributor or dealer. No representative of AKW is authorized to give or make any other representation or warranty or modify any warranty in any way. The provisions of these warranties do not apply to products: a) used for purposes for which they are not designed or intended; b) which have been subjected to alteration, abuse, misuse, negligence, or accident; c) which have been improperly stored, installed, maintained, or operated; d) which have been damaged due to neglect or lack of proper maintenance, cleaning, or care; e) which have been damaged due to the use of inappropriate cleaners, solvents, abrasives, or other chemical or mechanical causes. Proof of

purchase is required for any warranty claim. Products shipped to AKW for warranty service, replacement, or refund, that were not purchased from an authorized AKW distributor or dealer, will not qualify for warranty service, and AKW will hold such products only for a limited time and ship them back at the sender's cost upon their request after shipping and handling fees have been prepaid. The Buyer's sole and exclusive remedy against AKW for any cause of action arising out of the sale or use of any product purchased from AKW shall be replacement of the product or refund of the purchase price paid for the product. In no event shall AKW be liable for special, indirect, incidental, or consequential damages howsoever arising, including without limitation, lost revenues or profits, labor costs, shipping and freight costs, or expenses incurred due to the installation, removal, or replacement of any product. Any cause of action for breach of warranty must be brought by the Buyer, if at all, within one (1) year from the date the cause of action occurred. Any discrepancy in pricing or other charges shall be deemed waived by the Buyer unless the Buyer notifies AKW thereof in writing within sixty (60) days from the date of invoice on which such disputed transaction is reflected. In no event shall AKW have any responsibility or liability to a Buyer for any failure or delay in performance by AKW which results, directly or indirectly, in whole or in part, from any cause or circumstance beyond the reasonable control of AKW. Such causes and circumstances shall include, but are not limited to, acts of God, acts of Buyer, acts or orders of any governmental authority, strikes or other labor disputes, natural disasters, accidents, wars, civil disturbances, unavailability of supplies from usual suppliers, difficulties or delays in transportation, mail or delivery services, or any other cause beyond AKW's reasonable control.

## SOLE AGREEMENT AND INTERPRETATION

The Terms and Conditions set forth herein, together with any additions or revisions which may be agreed in writing by AKW, embody the whole agreement of the parties and provide the only remedies available. There are no promises, terms, conditions, understandings, obligations, or agreements other than those contained herein. These Terms and Conditions, and any transactions or agreements to which they apply, shall be governed both as to interpretation and performance by the laws of the State of Wisconsin. The only remedies available. There are no promises, terms, conditions, understandings, obligations, or agreements other than those contained herein. These Terms and Conditions, and any transactions or agreements to which they apply, shall be governed both as to interpretation and performance by the laws of the State of Wisconsin.



## Resource Center

### General Inquiries

1-715-743-2771

info@akwresourcecenter.com

### AKW Resource Center

7 Tiff Ave.

Neillsville,

WI 54456

[akwresourcecenter.com](http://akwresourcecenter.com)



Proud member of

