

## Tuff Form8 Shower Bases

### Product Overview

Pre-sloped Tuff Form8 Shower Bases are made from lightweight yet strong compression molded glass-fiber reinforced plastic (GRP) and can support up to 840lbs without modifying joists.

The octagonal rotating drain plate enables you to change the drain position to avoid joists or obstructions, with up to 15 different positions achievable\*. Once installed and waterproofed, bases can be finished with decorative tile, stone, or weldable vinyl flooring.

Tuff Form8 bases offer the timeless advantage of level-entry access, which makes the shower easier to clean, safer to use, and more accessible to seniors, people with health conditions, or those in wheelchairs.

### Features & Benefits

- + Made from lightweight yet strong compression molded glass-fiber reinforced plastic (GRP), ideal for accessible showers
- + Install on wood or engineered joist systems, on subfloor, or concrete
- + Can support up to 840lbs when installed on 16" o.c. joist systems supplemented with perimeter and drain hole blocking
- + Curbless, barrier-free design increases safety by reducing trip hazards and providing access for seniors, people with disabilities, or those in wheelchairs
- + Waffle design on underside of base increases strength while reducing weight
- + Enlarge size of the shower base using AKW Pitch Extension Panels
- + Can be used to create an ADA compliant shower, seek guidance locally for more information about compliancy and building regulations
- + Cut and drill as needed with standard power tools; base can be trimmed on all sides (remain 6" from drain hole)

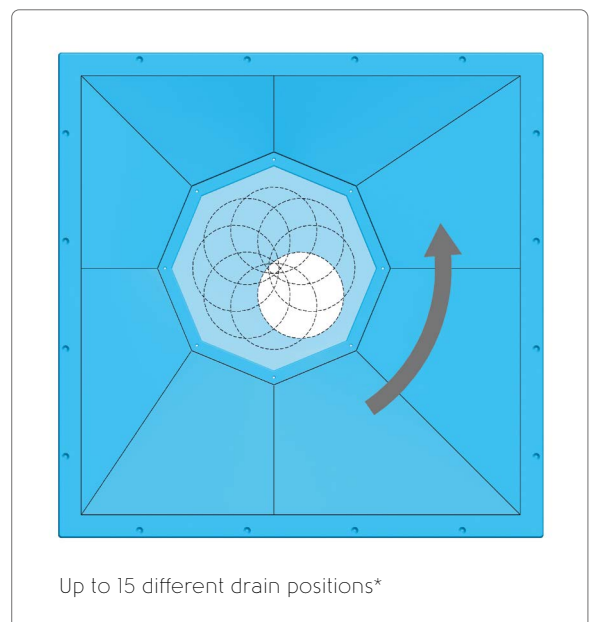
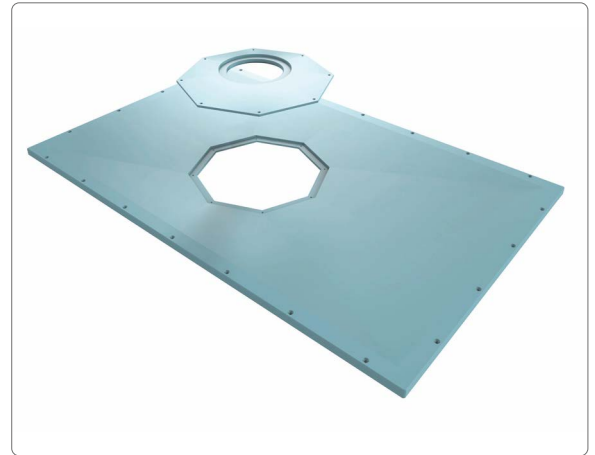

\*Rotate drain plate by 45° for 8 different drain positions, 7 further positions can be achieved by rotating base by 180° due to off-center design of drain plate.

### Features & Benefits (continued)

- + 4 pre-sloped gradient planes for quick, efficient drainage which reduces the risk of pooling or flooding
- + Octagonal drain plate with off-center drain hole enables you to avoid joists or obstructions by rotating the plate and/or base
- + Pre-drilled, countersunk pilot holes along perimeter for easy installation
- + Complete installation with an AKW Tuff Form Drain and Waterproofing Kit (available a la carte)
- + Finish with decorative tile, stone, or weldable vinyl flooring
- + Durable and re-useable; remove and replace tile without damaging the structure of the base

### Technical Specification

- + Size Options: 9
- + Material: Compression molded glass-fiber reinforced plastic (GRP)
- + Weight capacity: 840lbs
- + Weight: approx. 30lbs (depending on size)
- + Gradient:  $\geq 2\%$  per foot (depending on length of pitch)
- + Spans 16" o.c. joist systems
- + Perimeter:  $\frac{7}{8}$ " thick
- + Drain hole diameter:  $6\frac{1}{4}$ "
- + Compatible with standard 2" drain connectors
- + Suitable for use with underfloor heating
- + Can be finished with tile, stone or weldable vinyl flooring

### Compliance

#### a. ICC PMG-1223 lists compliance with:

- 1 2015, 2012 and 2009 International Residential Code® (IRC)



- 2 2015, 2012 and 2009 International Plumbing Code® (IPC)
- 3 2015, 2012 and 2009 Uniform Plumbing Code® (UPC)
- 4 2010 and 2005 National Plumbing Code of Canada (NPC)
- 5 IAPMO PS106-2015e1 for prefabricated, tileable shower receptors
- 6 CSA B45.5/IAPMO Z124-2011, Plastic Plumbing Fixtures

#### b. QAI Laboratories test report no. RJ4241-1:

- 1 Meets conditions of classification for 30-minute flame spread index and smoke developed index per ASTM E84 requirements

### Warranty & Approvals

- + AKW Limited lifetime warranty
- + Can be used to create an ADA compliant shower



Dimensions

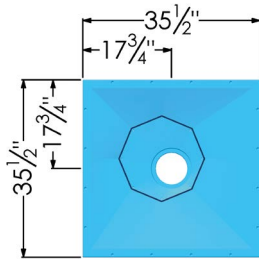

35 1/2" x 35 1/2"  
(Perimeter 7/8" thick)

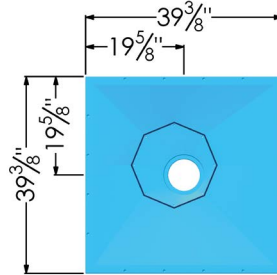

39 3/8" x 39 3/8"  
(Perimeter 7/8" thick)

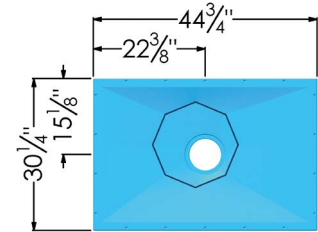

44 3/4" x 30 1/4"  
(Perimeter 7/8" thick)

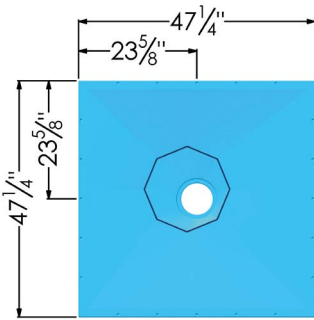

47 1/4" x 47 1/4"  
(Perimeter 7/8" thick)

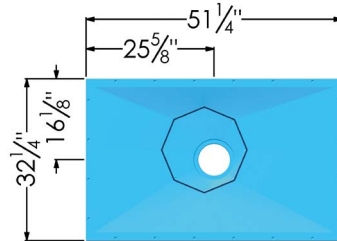

51 1/4" x 32 1/4"  
(Perimeter 7/8" thick)

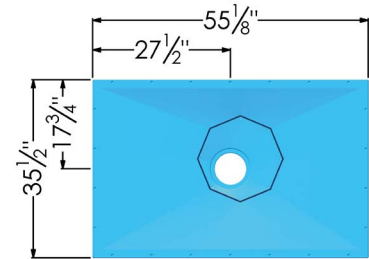

55 1/8" x 35 1/2"  
(Perimeter 7/8" thick)

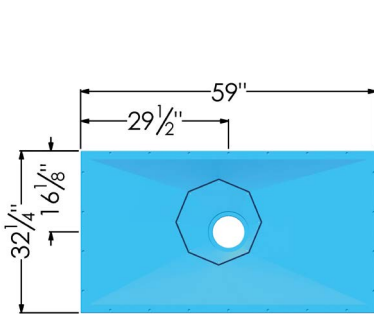

59" x 32 1/4"  
(Perimeter 7/8" thick)

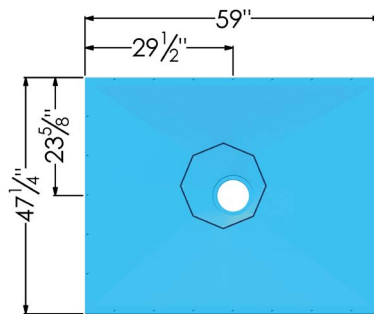

59" x 47 1/4"  
(Perimeter 7/8" thick)

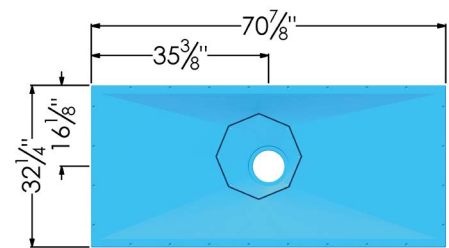

70 7/8" x 32 1/4"  
(Perimeter 7/8" thick)

**Product Codes**

**Tuff Form8 Shower Bases**

Tuff Form8 35 1/2" x 35 1/2"	21130
Tuff Form8 39 3/8" x 39 3/8"	21131
Tuff Form8 44 3/4" x 30 1/4"	21132
Tuff Form8 47 1/4" x 47 1/4"	21133
Tuff Form8 51 1/4" x 32 1/4"	21134
Tuff Form8 55 1/8" x 35 1/2"	21135
Tuff Form8 59" x 32 1/4"	21136
Tuff Form8 59" x 47 1/4"	21137
Tuff Form8 70 7/8" x 32 1/4"	21138

**Waterproofing Kits**

Premium Waterproofing Kit	WP1000-PRE
Pro Waterproofing Kit	WP1090-PRO

**Compatible Products**

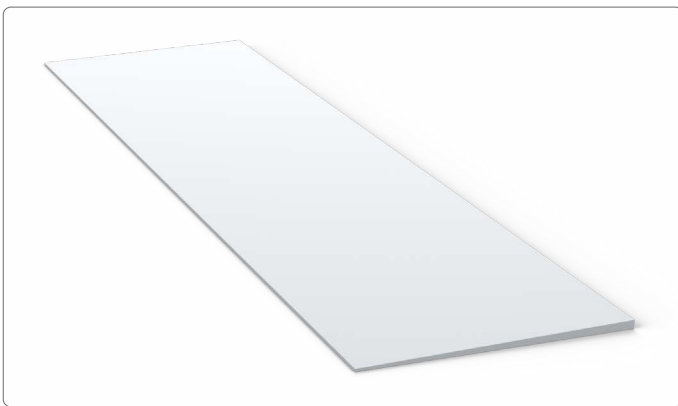

**Pitch Extension Panels**

Pre-sloped panels which allow you to extend the length/width of any Tuff Form8 base by an additional 12" – see specification for details.



**Tuff Form Drains**

Drains assemblies for Tuff Form8 shower bases available in multiple color choices and designs – see specification for details.