

Product Overview

Pre-sloped and structural TriForm Shower Bases can support up to 560lbs without modifying joists, benefit from a high-flow linear drain, and once waterproofed can be finished with decorative tile or stone.

TriForm bases offer the timeless advantage of level-entry access, which makes the shower easier to clean, safer to use, and more accessible to seniors, people with health conditions, or those in wheelchairs.

Features & Benefits

- + Made from fiberglass resin, marine-grade plywood, steel pipe and gel coat for strength and durability, ideal for accessible showers
- + Install on wood or engineered joist systems, on subfloor, or concrete
- + Can support up to 560lbs when installed on 16" o.c. joist systems supplemented with perimeter and drain hole blocking
- + Curbless, barrier-free design increases safety by reducing trip hazards and providing access for seniors, people with disabilities, or those in wheelchairs
- + Drill as needed with standard power tools; base cannot be cut and doing so will void the manufacturer warranty
- + Enlarge size of the shower base using AKW Pitch Extension Panels
- + Can be used to create an ADA compliant shower, seek guidance locally for more information about compliancy and building regulations
- + Flat perimeter for easier levelling during installation
- + 4 pre-sloped gradient planes for quick, efficient drainage which reduces the risk of pooling or flooding



- + Integrated drain gully with up to 3 outlets to connect to 2" drain line; gully must hang freely between joists and not be obstructed
- + Install multiple connectors to accommodate higher flow showers with volumes of up to 17 gallons per minute
- + Choice of heavy-gauge stainless-steel solid, slotted or tile-in linear drain covers in a variety of finishes
- + Tile-in drain covers can be tiled to match the rest of the shower floor for an enhanced cosmetic finish, and can accommodate tile between 1/4"-5/8" thick
- + All TriForm Drain Covers are supplied with a 2" drain connector, additional connectors are available a la carte
- + Complete installation with an AKW Waterproofing Kit (available a la carte)
- + Finish with decorative tile or stone
- + Durable and re-useable; remove and replace tile without damaging the structure of the base

Warranty & Approvals

- + AKW Limited lifetime warranty on Shower Base and Drain Assembly
- + 10-Year Sioux Chief warranty on Drain Connector
- + Can be used to create an ADA compliant shower



On Shower Base
and Drain Assembly



On Drain
Connector



Technical Specification

- + Size Options: 4
- + Material: Fiberglass resin, marine-grade plywood, steel pipe and gel coat
- + Weight capacity: 560lbs
- + Weight: approx. 50lbs (depending on size)
- + Gradient: $\geq 2\%$ per foot (depending on length of pitch)
- + Spans 16" o.c. joist systems
- + Perimeter: $\frac{7}{8}$ " thick
- + Drain hole diameter: 6"
- + Compatible with up to 3 standard 2" drain connectors
- + Requires a TriForm Drain Cover (a la carte)
- + 1 x 2" drain connector supplied with drain cover
- + Suitable for use with underfloor heating
- + Can be finished with tile or stone

Compliance

a. ICC PMG-1223 lists compliance with:

- 1 2015, 2012 and 2009 International Residential Code® (IRC)
- 2 2015, 2012 and 2009 International Plumbing Code® (IPC)
- 3 2015, 2012 and 2009 Uniform Plumbing Code® (UPC)
- 4 2010 and 2005 National Plumbing Code of Canada (NPC)
- 5 IAPMO PS106-2015e1 for prefabricated, tileable shower receptors
- 6 CSA B45.5/IAPMO Z124-2011, Plastic Plumbing Fixtures

b. QAI Laboratories test report no. RJ4241-1:

- 1 Meets conditions of classification for 30-minute flame spread index and smoke developed index per ASTM E84 requirements



Dimensions

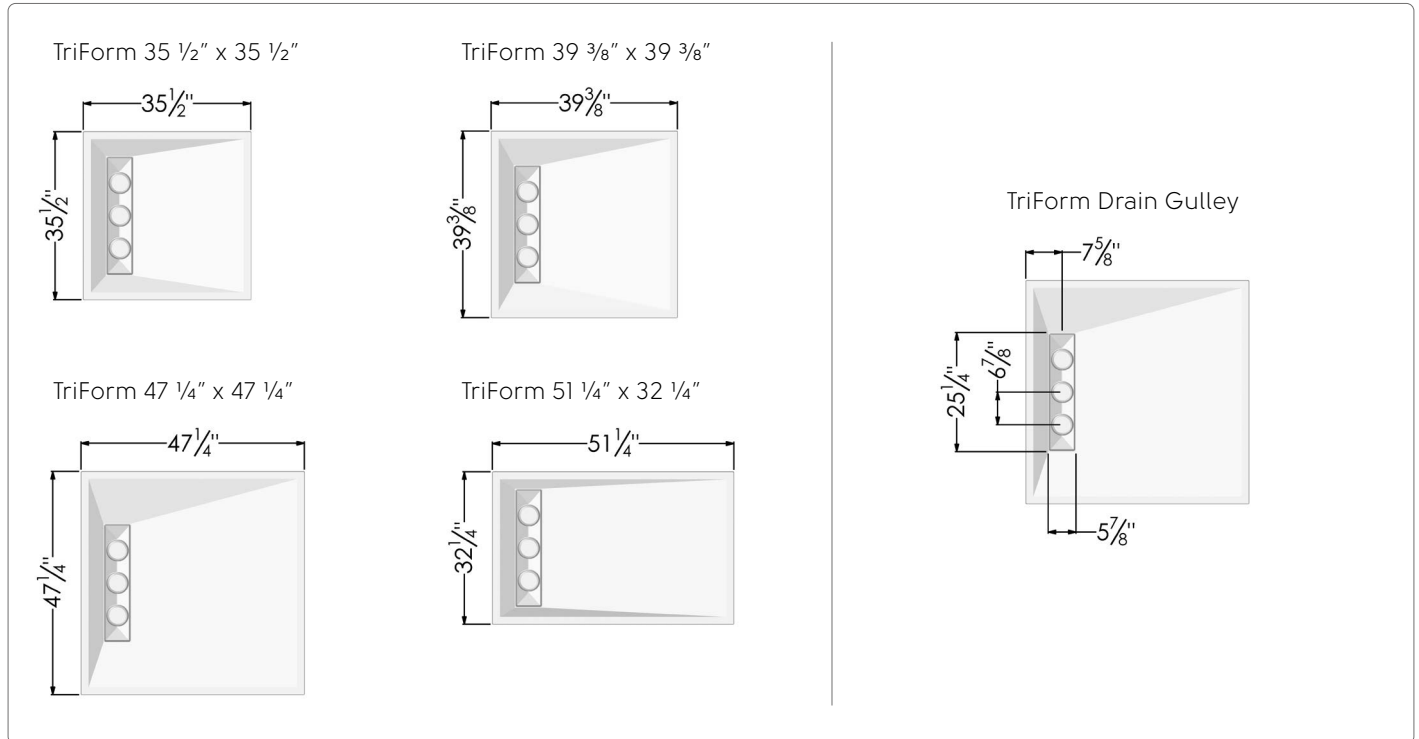

Product Codes

TriForm Shower Bases

TriForm 35 1/2" x 35 1/2"	21205
TriForm 39 3/8" x 39 3/8"	21206
TriForm 47 1/4" x 47 1/4"	21208
TriForm 51 1/4" x 32 1/4"	21207

Waterproofing Kits

Premium Waterproofing Kit	WP1000-PRE
Pro Waterproofing Kit	WP1090-PRO

TriForm Drain Covers & Connectors

TriForm Solid Drain Cover – Stainless Steel	21213
TriForm Solid Drain Cover – Oil-Rubbed Bronze	21213-ORB
TriForm Solid Drain Cover – Matte Black	21213-BK
TriForm Slotted Drain Cover – Stainless Steel	21215
TriForm Slotted Drain Cover – Oil-Rubbed Bronze	21215-ORB
TriForm Slotted Drain Cover – Matte Black	21215-BK
2" PVC Drain Connector	DC5500-PVC

Compatible Products

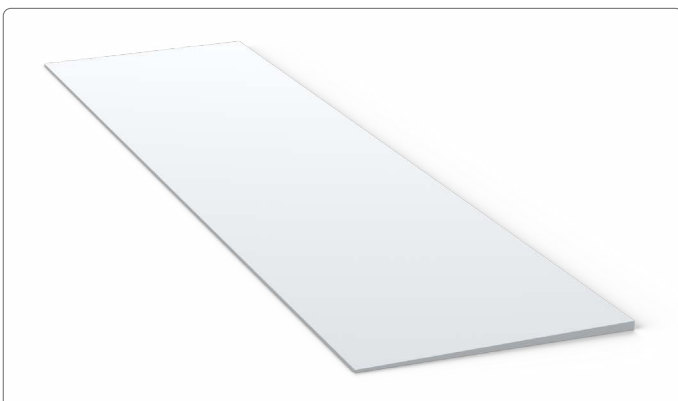

Pitch Extension Panels

Pre-sloped panels which allow you to extend the length/width of any TriForm base by an additional 12" – see specification for details.