

Product Overview

Increase the size of most AKW curbless shower bases by 12" per side with pre-sloped Pitch Extension Panels, which are an ideal substitution for tile backer boards or uncoupling membrane alongside a shower base.

Measuring 12" x 60" with a 1/4" per foot slope, extension panels can help to create ADA compliant showers to increase safety and accessibility for wheelchair users.

Features & Benefits

- + Extend the pitch of shower base on up to 4 sides; cannot be used to extend more than 12" per side
- + Made from lightweight yet strong PVC composite
- + Can be used to create an ADA compliant shower, seek guidance locally for more information about compliancy and building regulations
- + Cut and drill as needed with standard power tools; can be trimmed on all sides
- + Install on wood or engineered joist systems, on subfloor, or concrete
- + Secure panels to the subfloor using Tank/10 polyurethane construction adhesive (available a la carte) or modified thin-set mortar, and screws
- + Drill countersunk pilot holes 6-8" apart for screws
- + Complete installation with an AKW Waterproofing Kit (available a la carte)
- + Finish with decorative tile, stone, or weldable vinyl flooring

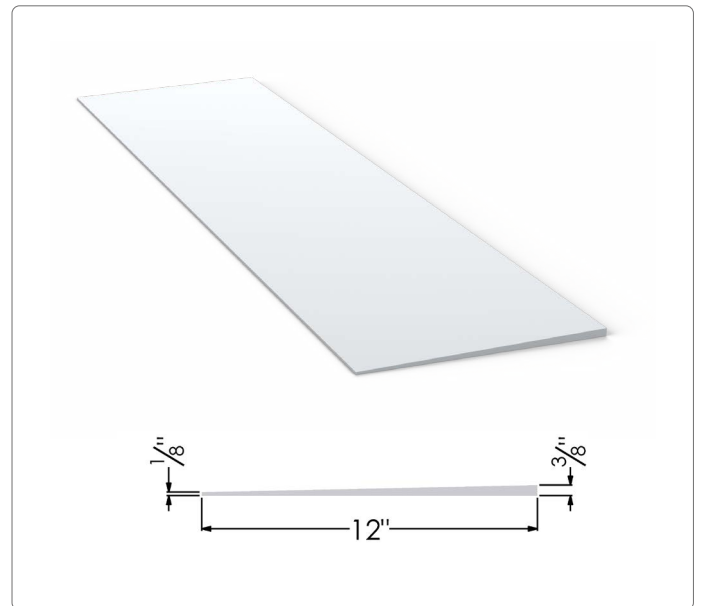

Technical Specification

- + Material: PVC
- + Size: 12" x 60"
- + Pitch: 1/4" per foot slope
- + Weight: approx. 7lbs
- + Compatible with AKW Tuff Form, Tuff Form8, Tuff Form Linear Tub Replacement, and TriForm Shower Bases
- + Suitable for use with underfloor heating
- + Can be finished with tile, stone or weldable vinyl flooring

Warranty & Approvals

- + AKW Limited lifetime warranty
- + Can be used to create an ADA compliant shower



Product Code

Pitch Extension Panel 12" x 60"

TB6012-PXT